

Flexim FLUXUS F601 Ultrasonic Flowmeter



Portable Ultrasonic Flow Measurement of Liquids

Features

- Flow measurement for all acoustically penetrable fluids
- Integrated thermal energy measurement for all typical heat and refrigerating agents
- Temperature range -40...+200 °C, with WaveInjector max. +630 °C
- Precise bidirectional and highly dynamic flow measurement with the non-invasive clamp-on technology
- Calibrated transducers and transmitters with traceable certificates
- Automatic loading of calibration data and transducer detection for a fast and easy set-up (less than 5 min), providing precise and long-term stable results
- High precision at fast and slow flow rates, high temperature and zero point stability
- Portable, easy-to-use flow transmitter with 2 flow channels, multiple inputs/outputs, an integrated data logger
- Integrated wall thickness measurement with connectable wall thickness probe
- The transmitter is water and dust-tight (IP65), resistant against oil, many liquids and dirt
- Li-Ion battery provides up to 25 hours of measurement operation

Applications

Designed for harsh environments and applicable in all areas such as drinking water and sewerage industry, power plants, producing industry, food industry and many more. Example applications:

- Operation measurements
- Data gathering in energy management and certifications according to ISO 50001
- Survey of pump performances
- Hydraulic balancing
- Verification of installed measuring systems
- Supervision of permanently installed meters, service and maintenance

Function	3
Measurement principle	3
Calculation of volumetric flow rate	3
Number of sound paths	4
Typical measurement setup	5
Transmitter	6
Technical data	6
Dimensions	7
Storage	8
Standard scope of supply	8
Adapters	9
Example of transport case equipment	10
Transducers	11
Transducer selection	11
Transducer order code	12
Technical data	13
Transducer mounting fixture	15
Coupling materials for transducers	18
Connection systems	19
Clamp-on temperature probe (optional)	20
Technical data	20
Fixation	21
Wall thickness measurement (optional)	22
Technical data	22

Function

Measurement principle

The transducers are mounted on the pipe which is completely filled with the fluid. The ultrasonic signals are emitted alternately by a transducer and received by the other. The physical quantities are determined from the transit times of the ultrasonic signals.

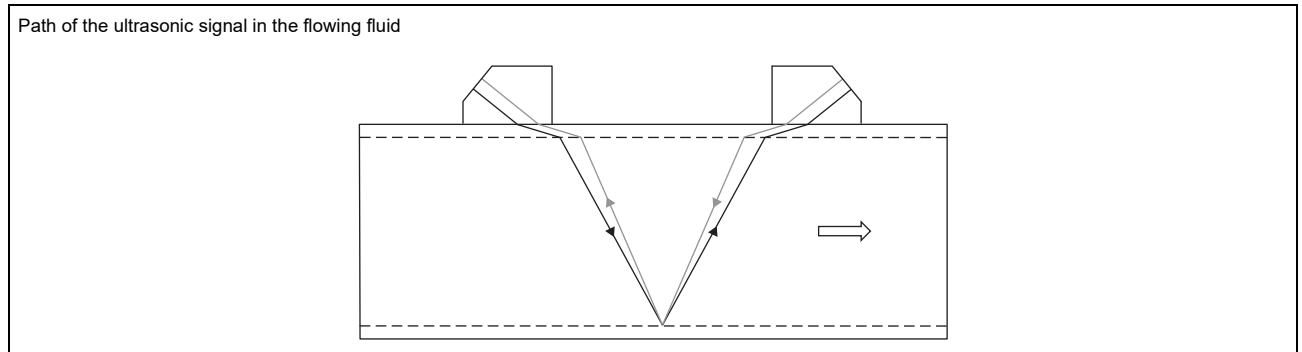

Transit time difference principle

As the fluid where the ultrasound propagates is flowing, the transit time of the ultrasonic signal in flow direction is shorter than the one against the flow direction.

The transit time difference Δt is measured and allows the flowmeter to determine the average flow velocity along the propagation path of the ultrasonic signals. A flow profile correction is then performed in order to obtain the area averaged flow velocity, which is proportional to the volumetric flow rate.

The integrated microprocessors control the entire measuring cycle. The received ultrasonic signals are checked for measurement usability and evaluated for their reliability. Noise signals are eliminated.

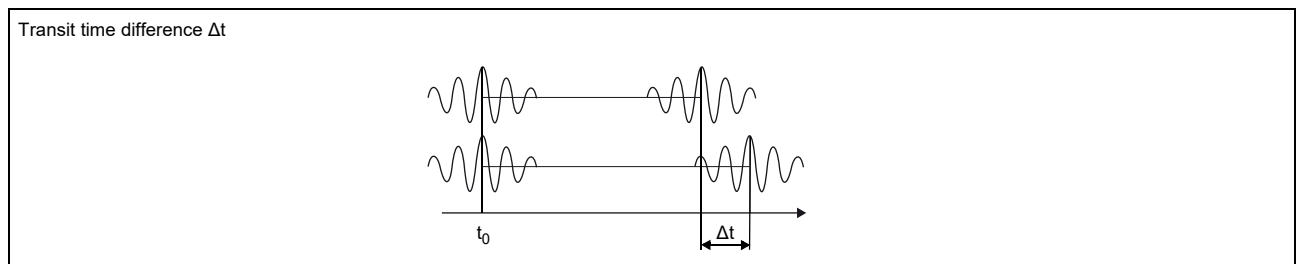

HybridTrek

If the gaseous or solid content in the fluid increases occasionally during measurement, a measurement with the transit time difference principle is no longer possible. NoiseTrek mode will then be selected by the flowmeter. This measurement method allows the flowmeter to achieve a stable measurement even with high gaseous or solid content.

The transmitter automatically toggles between the TransitTime and the NoiseTrek mode without having to change the measuring setup.

Calculation of volumetric flow rate

$$\dot{V} = k_{Re} \cdot A \cdot k_a \cdot \frac{\Delta t}{2 \cdot t_y}$$

where

- \dot{V} - volumetric flow rate
- k_{Re} - fluid mechanic calibration factor
- A - cross-sectional pipe area
- k_a - acoustic calibration factor
- Δt - transit time difference
- t_y - average of transit times in the fluid

Number of sound paths

The number of sound paths is the number of transits of the ultrasonic signal through the fluid in the pipe. Depending on the number of sound paths, the following methods of installation exist:

- **reflection arrangement**

The number of sound paths is even. The transducers are mounted on the same side of the pipe. Correct positioning of the transducers is easy.

- **diagonal arrangement**

The number of sound paths is odd. The transducers are mounted on opposite sides of the pipe. In case of high signal attenuation by the fluid or pipe, diagonal arrangement with 1 sound path is used.

The preferred method of installation depends on the application. While increasing the number of sound paths increases the accuracy of the measurement, signal attenuation increases as well. The optimum number of sound paths for the parameters of the application will be determined automatically by the transmitter.

As the transducers can be mounted with the transducer mounting fixture in reflection arrangement or diagonal arrangement, the number of sound paths can be adjusted optimally for the application.

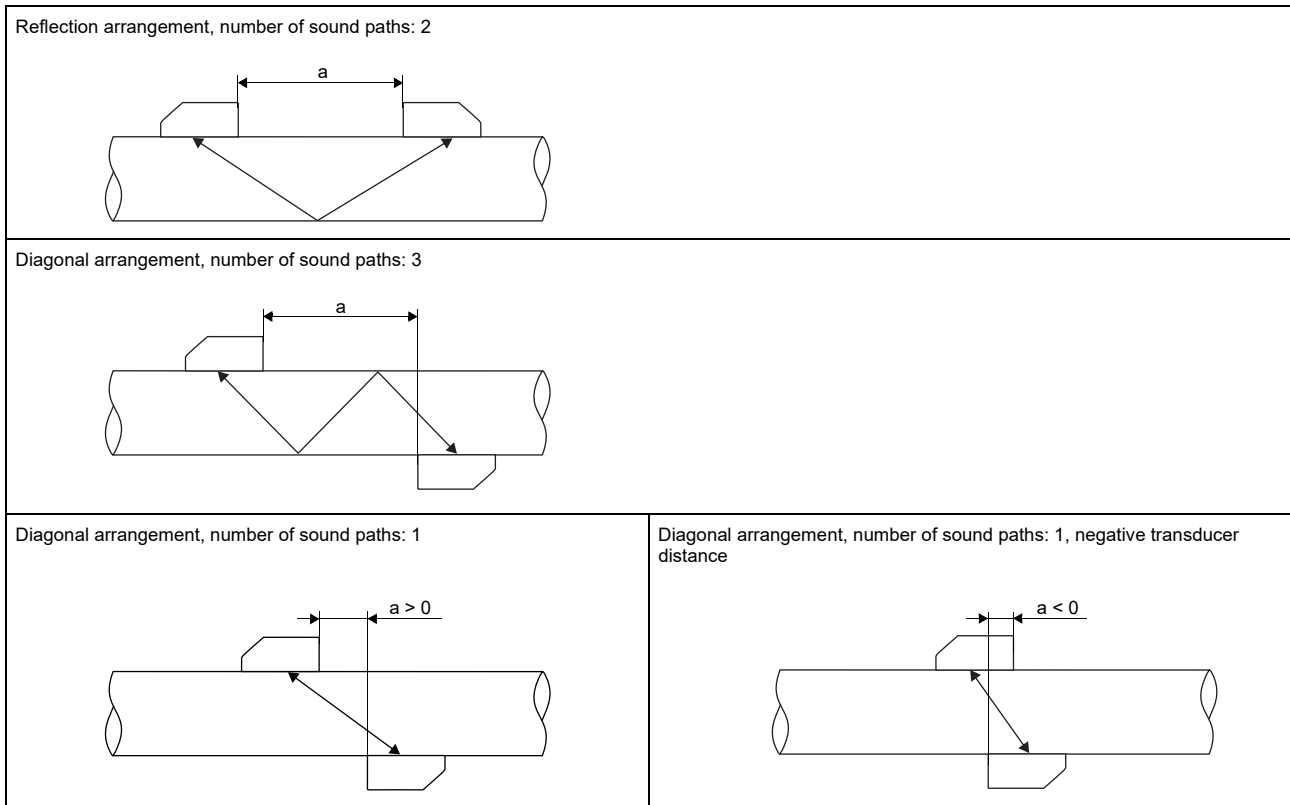

a - transducer distance

Typical measurement setup

Example of a reflection arrangement

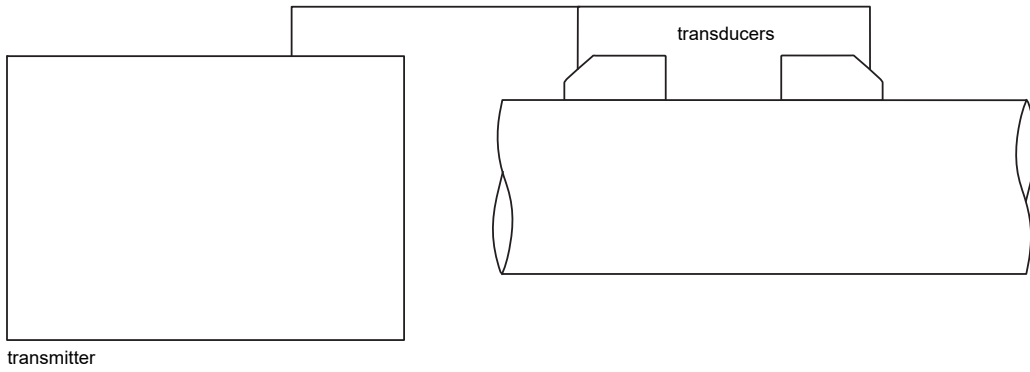

Example of a thermal energy rate measurement measuring the volumetric flow rate in the return line

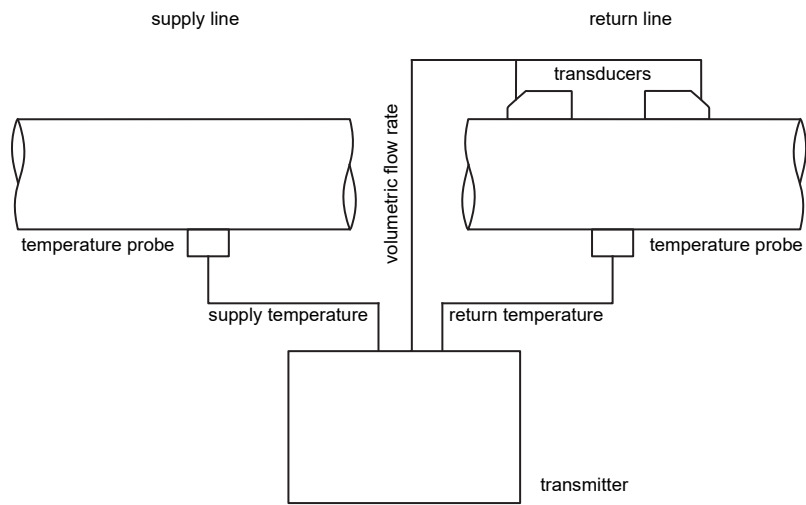

Transmitter

Technical data

FLUXUS F601	
	
design	portable
measurement	
measurement principle	transit time difference correlation principle, automatic NoiseTrek selection for measurements with high gaseous or solid content
flow direction	bidirectional
flow velocity	m/s 0.01...25
repeatability	0.15 % MV ±0.005 m/s
fluid	all acoustically conductive liquids with < 10 % gaseous or solid content in volume (transit time difference principle)
temperature compensation	corresponding to the recommendations in ANSI/ASME MFC-5.1-2011
measurement uncertainty (volumetric flow rate)	
measurement uncertainty of the measuring system ¹	±0.3 % MV ±0.005 m/s
measurement uncertainty at the measuring point ²	±1 % MV ±0.005 m/s
transmitter	
power supply	<ul style="list-style-type: none"> 100...230 V/50...60 Hz (power supply unit: IP40, 0...40 °C) 10.5...15 V DC (socket at transmitter) integrated battery
integrated battery • operating time	h > 14 (without outputs, inputs and backlight) ³ > 25 (1 measuring channel, ambient temperature > 10 °C, without outputs, inputs and backlight) ³
power consumption	W < 6 (with outputs, inputs and backlight), charging: 18
number of measuring channels	2
damping	s 0...100 (adjustable)
measuring cycle	Hz 100...1000 (1 channel)
response time	s 1 (1 channel), option: 0.07
housing material	PA, TPE, AutoTex, stainless steel
degree of protection	IP65
dimensions	mm see dimensional drawing
weight	kg 2.1
fixation	QuickFix pipe mounting fixture
ambient temperature	°C -10...+60
display	2 x 16 characters, dot matrix, backlight
menu language	English, German, French, Dutch, Spanish
measuring functions	
physical quantities	volumetric flow rate, mass flow rate, flow velocity, thermal energy rate (if temperature inputs are installed)
totaliser	volume, mass, optional: thermal energy
calculation functions	average, difference, sum
diagnostic functions	sound speed, signal amplitude, SNR, SCNR, standard deviation of amplitudes and transit times
communication interfaces	
service interfaces	<ul style="list-style-type: none"> RS232 USB (with adapter)
process interfaces	<ul style="list-style-type: none"> Modbus RTU (optional)
accessories	
data transmission kit • cable • adapter	RS232 RS232 - USB
software	<ul style="list-style-type: none"> FluxDiagReader: reading of measured values and parameters, graphical representation FluxDiag (optional): reading of measurement data, graphical representation, report generation
adapter	AO5, AO6, AO7, AO8, AI1, AI2
transport case	dimensions: 500 x 400 x 190 mm
data logger	
loggable values	all physical quantities, totalised physical quantities and diagnostic values
capacity	> 100 000 measured values

¹ with aperture calibration of the transducers

² for transit time difference principle and reference conditions

³ operating time extension using the power pack PP0026NN (optional, order code: ACC-PO-#601-/B6)

FLUXUS F601	
outputs	
	The outputs are galvanically isolated from the transmitter.
number	see standard scope of supply, max. on request
• switchable current output	
	All switchable current outputs are jointly switched to active or passive.
range	mA 4...20 (3.2...24)
accuracy	0.04 % MV ±3 µA
active output	$U_{int} = 24 \text{ V}$, $U_{opencircuit} = 28 \text{ V}$ (open circuit), $R_{ext} < 500 \Omega$
passive output	$U_{ext} = 8...30 \text{ V}$, depending on R_{ext} ($R_{ext} < 900 \Omega$ at 30 V)
• frequency output	
range	kHz 0...5
open collector	24 V/4 mA
• binary output	
optorelay	26 V/100 mA
binary output as alarm output	
• functions	limit, change of flow direction or error
binary output as pulse output	
• functions	mainly for totalising
• pulse value	units 0.01...1000
• pulse width	ms 1...1000
inputs	
	The inputs are galvanically isolated from the transmitter.
number	see standard scope of supply, max. 4
• temperature input	
type	Pt100/Pt1000
connection	4-wire
range	°C -150...+560
resolution	K 0.01
accuracy	±0.01 % MV ±0.03 K
• current input	
accuracy	0.1 % MV ±10 µA
passive input	$R_{int} = 50 \Omega$, $P_{int} < 0.3 \text{ W}$
• range	mA -20...+20
• voltage input	
range	V 0...1
accuracy	0.1 % MV ±1 mV
internal resistance	$R_{int} = 1 \text{ M}\Omega$

¹ with aperture calibration of the transducers

² for transit time difference principle and reference conditions

³ operating time extension using the power pack PP0026NN (optional, order code: ACC-PO-#601/B6)

Dimensions

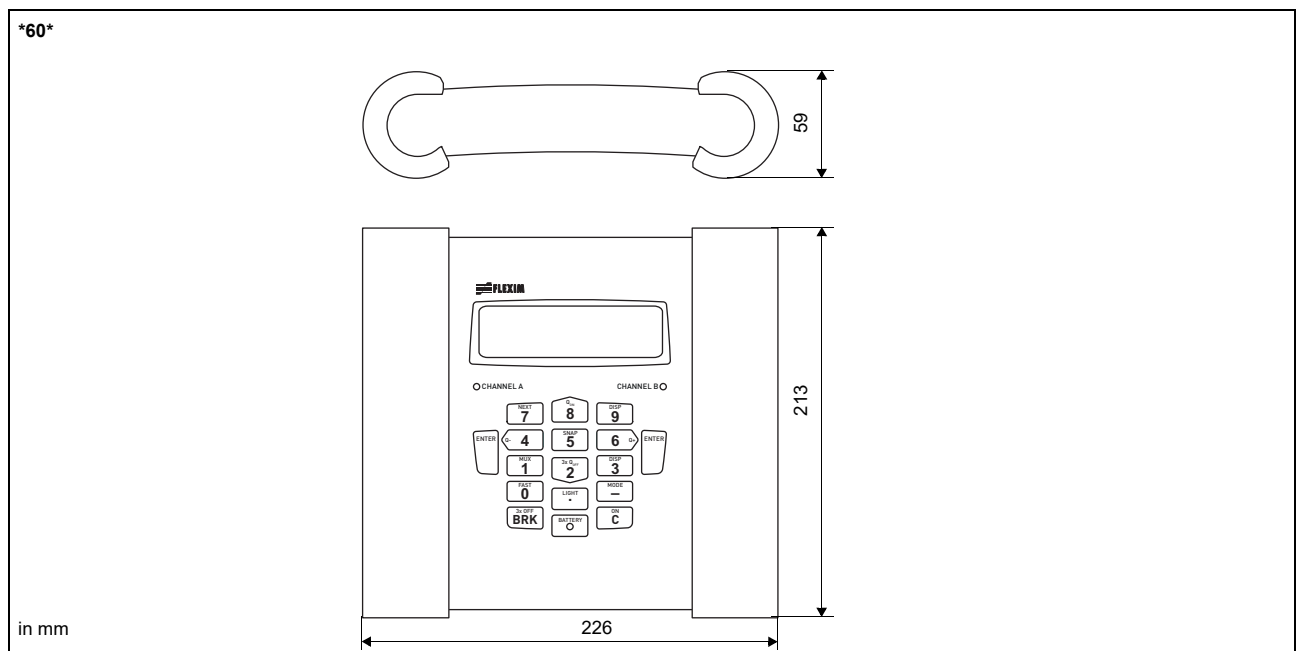

Storage

- do not store outdoors
- store within the original package
- store in a dry and dust-free place
- protect against sunlight
- keep all openings closed
- storing temperature: -10...+60 °C

Standard scope of supply

	F601 Basic	F601 Energy
application	flow measurement of liquids	
	2 independent measuring channels, 2 calculation channels	
	wall thickness measurement (wall thickness probe to be ordered separately)	
		integrated thermal energy calculator
		simultaneous monitoring of 2 energy flows
	temperature-compensated calculation of mass flow rate	
outputs		
switchable current output	2	2
inputs		
temperature input	-	4
accessories		
transport case	x	x
power supply unit, mains cable	x	x
battery	x	x
adapter	AO6	AO6
QuickFix pipe mounting fixture for transmitter	x	x
data transmission kit	x	x
measuring tape	x	x
operating instruction, Quick start guide	x	x

Adapters

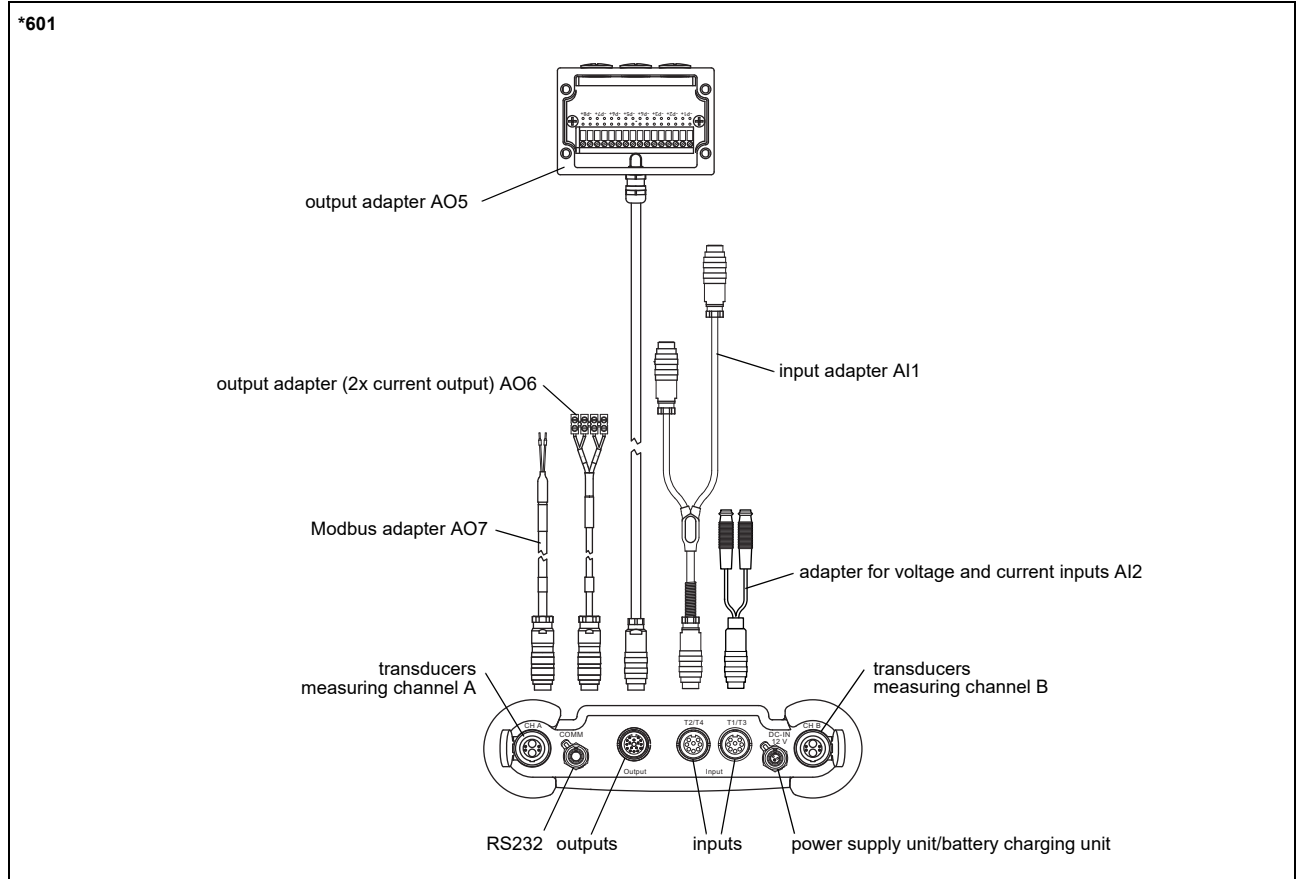

Example of transport case equipment



Transducers

Transducer selection

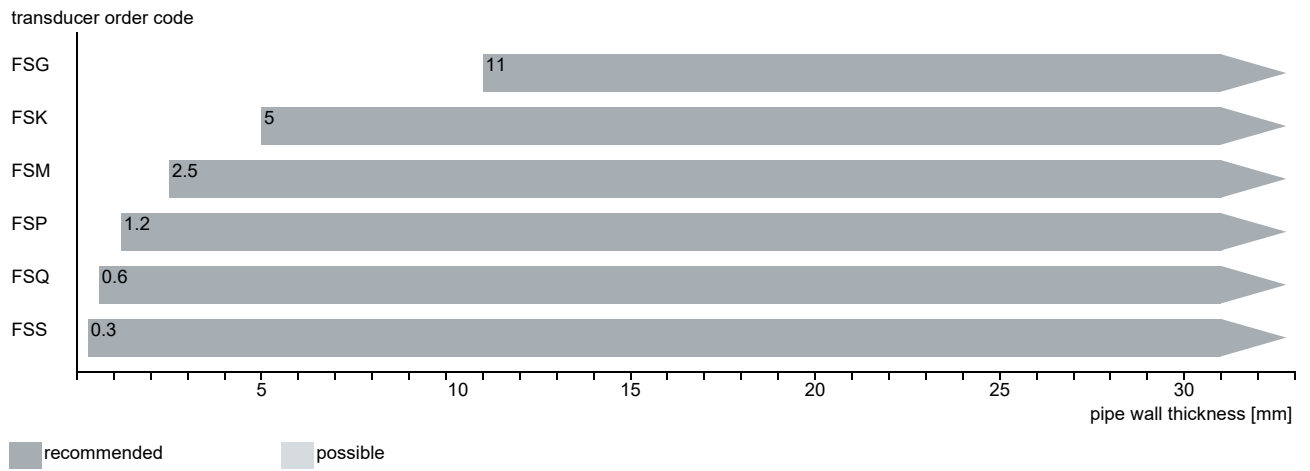
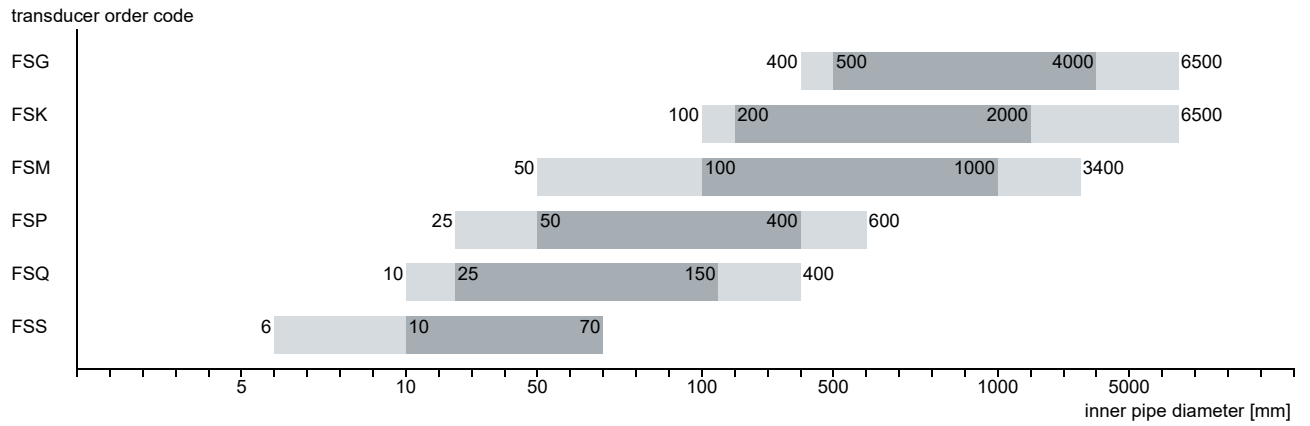

Transducer order code

1, 2	3	4	5...7	8, 9	10, 11	12...14	no. of character
transducer	transducer frequency	-	ambient temperature	explosion protection	-	certification	connection system
-	-	-	-	-	-	-	cable length
							description
FS							set of ultrasonic flow transducers for Measurement of Liquids, shear wave
G							0.2 MHz
K							0.5 MHz
M							1 MHz
P							2 MHz
Q							4 MHz
S							8 MHz
N							normal temperature range
E							extended temperature range
NNN							not explosion-proof
**							
NL							with LEMO connector
***							in m

Technical data

Shear wave transducers (nonEx, NL)

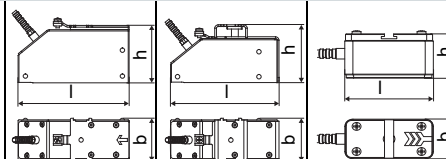
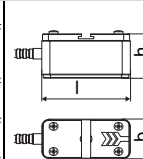
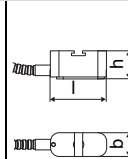
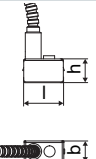
order code		FSG-NNNN-**NL	FSK-NNNN-**NL	FSM-NNNN-**NL	FSP-NNNN-**NL	FSQ-NNNN-**NL	FSS-NNNN-**NL	
technical type		C(DL)G1NZ7	C(DL)K1NZ7	C(DL)M1NZ7	C(DL)P1NZ7	C(DL)Q1NZ7	CDS1NZ7	
transducer frequency	MHz	0.2	0.5	1	2	4	8	
inner pipe diameter d								
min. extended	mm	400	100	50	25	10	6	
min. recommended	mm	500	200	100	50	25	10	
max. recommended	mm	4000	2000	1000	400	150	70	
max. extended	mm	6500	6500	3400	600	400	70	
pipe wall thickness								
min.	mm	11	5	2.5	1.2	0.6	0.3	
material								
housing		PEEK with stainless steel cover 304 (1.4301)		stainless steel 304 (1.4301)		stainless steel 304 (1.4301)		
contact surface		PEEK		PEEK		PEI		
degree of protection		IP66		IP66		IP66		
transducer cable								
type		1699						
length	m	5		4	3	2		
dimensions								
length l	mm	129.5	126.5	60	42.5	25		
width b	mm	51	51	30	18	13		
height h	mm	67	67.5	33.5	21.5	17		
dimensional drawing								
weight (without cable)	kg	0.47	0.36	0.035	0.011	0.004		
pipe surface temperature	°C	-40...+130					-30...+130	
ambient temperature	°C	-40...+130					-30...+130	
temperature compensation		x						

Shear wave transducers (nonEx, NL, extended temperature range)

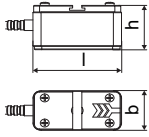
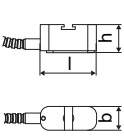
order code		FSM-ENNN-**NL	FSP-ENNN-**NL	FSQ-ENNN-**NL
technical type		C(DL)M1EZ7	C(DL)P1EZ7	C(DL)Q1EZ7
transducer frequency	MHz	1	2	4
inner pipe diameter d				
min. extended	mm	50	25	10
min. recommended	mm	100	50	25
max. recommended	mm	1000	400	150
max. extended	mm	3400	600	400
pipe wall thickness				
min.	mm	2.5	1.2	0.6
material				
housing		stainless steel 304 (1.4301)		
contact surface		Sintimid		
degree of protection		IP66		
transducer cable				
type		1699		
length	m	4		3
dimensions				
length l	mm	60		42.5
width b	mm	30		18
height h	mm	33.5		21.5
dimensional drawing				
weight (without cable)	kg	0.042		0.011
pipe surface temperature	°C	-30...+200		
ambient temperature	°C	-30...+200		
temperature compensation		x		

Transducer mounting fixture

Order code

1, 2 3 4 5 6 7...10 no. of character

transducer mounting fixture	transducer	measurement arrangement	size	fixation	outer pipe diameter	description
FS						fastening shoes
VP						portable Variofix
WN						WaveInjector WI-550
WH						WaveInjector WI-630
	A					all transducers
	G					transducers with transducer frequency G
	K					transducers with transducer frequency K
	M					transducers with transducer frequency M
	P					transducers with transducer frequency P
	Q					transducers with transducer frequency Q
	S					transducers with transducer frequency S
		D				reflection arrangement or diagonal arrangement
		R				reflection arrangement
			S			small
			M			medium
				C		chains
				G		tension belts
					0060	10...60 mm
					0100	10...100 mm
					0250	10...250 mm
					0550	10...550 mm
					0600	50...600 mm
					1500	50...1500 mm
					2100	50...2100 mm

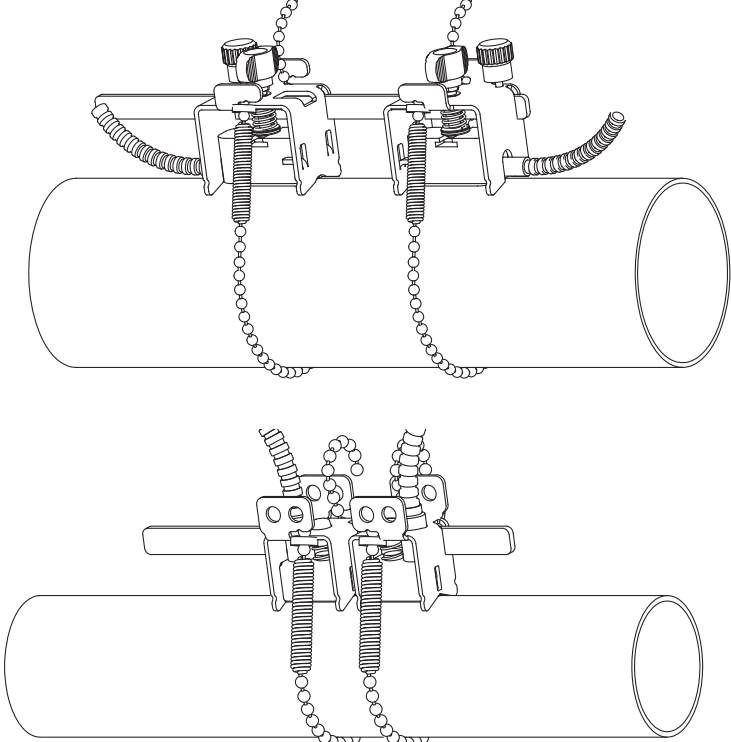
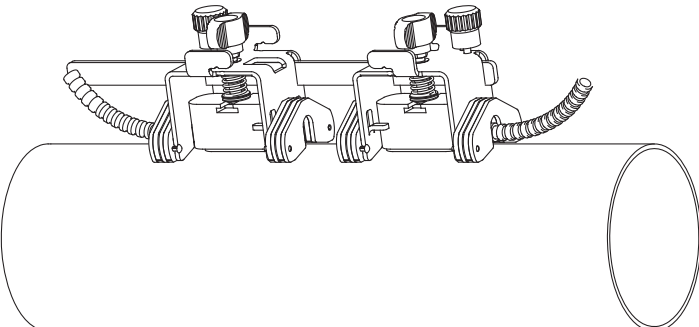
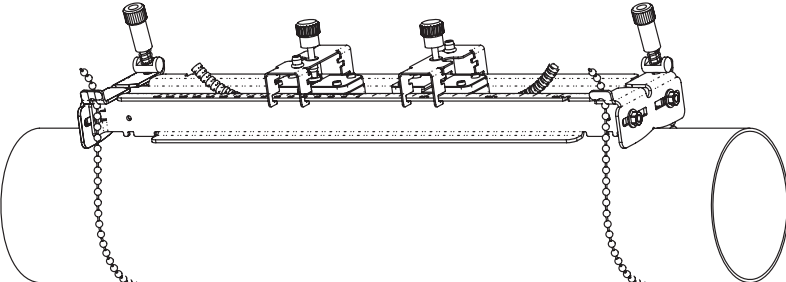
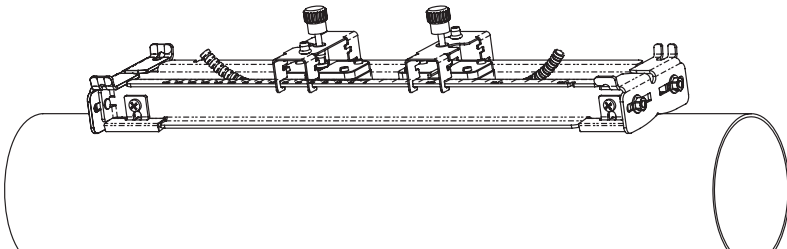
<p>fastening shoes FS and chains</p> 	<p>transducer frequency: M, P, Q</p> <p>material: stainless steel 304 (1.4301), 301 (1.4310), 303 (1.4305)</p> <p>dimensions: M, P: 420 x 48 x 68 mm Q: 420 x 43 x 58 mm</p> <p>chain length: 0.5/1/2 m</p> <p>outer pipe diameter: max. 150/310/600 mm</p> <p>transducer frequency: S</p> <p>material: stainless steel 304 (1.4301), 301 (1.4310), 303 (1.4305)</p> <p>dimensions: 210 x 32 x 44 mm</p> <p>chain length: 0.5 m</p> <p>outer pipe diameter: max. 150 mm</p>
<p>fastening shoes FS and magnet (optional)</p> 	<p>material: stainless steel 304 (1.4301), 301 (1.4310), 303 (1.4305)</p> <p>dimensions: M, P: 420 x 48 x 68 mm Q: 420 x 43 x 58 mm</p>
<p>portable Variofix VP and chains</p> 	<p>material: stainless steel 304 (1.4301), 301 (1.4310), 303 (1.4305)</p> <p>dimensions: 414 x 94 x 76 mm</p> <p>chain length: 2 m</p>
<p>portable Variofix VP and magnet (optional)</p> 	<p>material: stainless steel 304 (1.4301), 301 (1.4310), 303 (1.4305)</p> <p>dimensions: 414 x 94 x 40 mm</p>

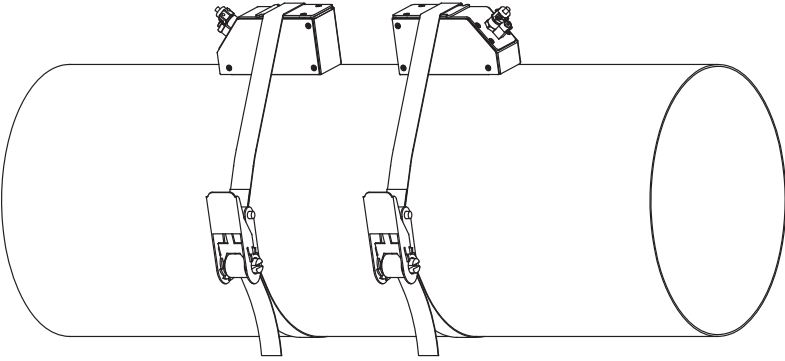
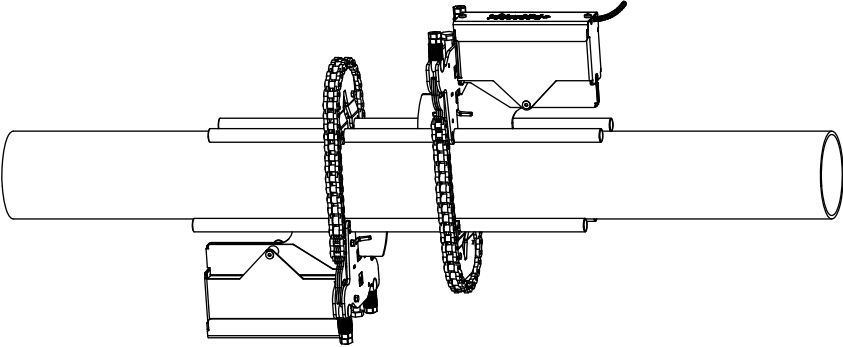
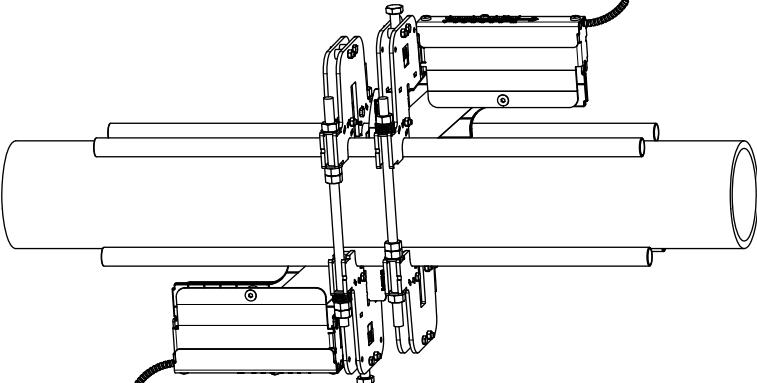
<p>tension belts</p> 	<p>transducer frequency: G, K</p> <p>material: steel, powder coated and textile tension belt</p> <p>length: 5/7 m</p> <p>ambient temperature: max. 60 °C</p> <p>outer pipe diameter: max. 1500/2100 mm</p>
<p>Waveinjector with chains</p> 	<p>see Technical specification TSWaveInjectorVx-x</p>
<p>Waveinjector with threaded rods</p> 	<p>outer pipe diameter: 35...380 mm</p> <p>see Technical specification TSWaveInjectorVx-x</p>

Coupling materials for transducers

normal temperature range (4th character of transducer order code = N)		extended temperature range higher temperatures (4th character of transducer order code = E, S)		WaveInjector	
< 100 °C	< 130 °C	< 180 °C	< 200 °C	< 280 °C	280...630 °C
coupling compound type N	coupling compound type N or E	coupling compound type E	coupling compound type E	coupling foil type A and coupling foil type VT	coupling foil type B and coupling foil type VT

Technical data

type	ambient temperature °C	remark
coupling compound type N	-30...+130	
coupling compound type E	-30...+200	
coupling foil type A	max. 280	
coupling foil type B	280...630	
coupling foil type VT	-10...+200	fluid temperature 200 °C: min. 2 years

coupling foil not to be used for transducer mounting fixture with magnets

Connection systems

connection system NL	
direct connection/connection with extension cable	transducers technical type
	*****Z7

Cable

transducer cable		
type		1699
weight	kg/m	0.094
ambient temperature	°C	-55...+200
cable jacket		
material		PTFE
outer diameter	mm	2.9
thickness	mm	0.3
colour		brown
shield		x
sheath		
material		stainless steel 316Ti (1.4571)
outer diameter	mm	8

extension cable				
type		1750	2551	
standard length	m	5 10	-	
max. length	m	10	see table below	
weight	kg/m	0.12	0.083	
ambient temperature	°C	< 80	-25...+80	
cable jacket				
material		PE	TPE-O	
outer diameter	mm	6	8	
thickness	mm	0.5		
colour		black	black	
shield		x	x	
sheath				
material		stainless steel 304 (1.4301)	-	
outer diameter	mm	9	-	
remark		optional		

Cable length

transducer frequency	F, G, H, K			M, P			Q			S			
	x	y	l	x	y	l	x	y	l	x	y	l	
*D***Z7 ¹	m	2	3	≤ 25	2	2	≤ 25	2	1	≤ 25	1	1	≤ 20
*L***Z7 ¹	m	2	7	≤ 25	7	2	≤ 25	8	1	≤ 25	-	-	-

¹ l > 25...100 m on request

x, y - transducer cable length

l - max. length of extension cable

Clamp-on temperature probe (optional)

Technical data

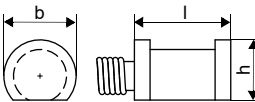
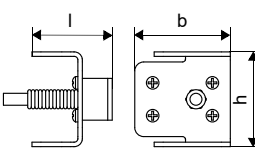
PT12N	
item number	<ul style="list-style-type: none"> 670415-1 670414-1 (matched)
design	clamp-on with connector
type	Pt100
connection	4-wire
measuring range	-30...+250 °C
accuracy T	$\pm(0.15 \text{ °C} + 2 \cdot 10^{-3} \cdot T \text{ [°C]})$ class A
accuracy ΔT (2x Pt matched according to EN 1434-1)	$\leq 0.1 \text{ K}$ ($3 \text{ K} < \Delta T < 6 \text{ K}$), more corresponding to EN 1434-1
response time	s 50 (t_{50} , $T_1 = 25 \text{ °C}$, $T_2 = 60 \text{ °C}$)
housing material	aluminum
degree of protection	IP54
dimensions	
length l	mm 20
width b	mm 15
height h	mm 13
dimensional drawing	
weight	kg 0.25 (without connector)
accessories	
thermal conductivity paste 200 °C	x
thermal conductivity foil 250 °C	x
PT12F	
item number	<ul style="list-style-type: none"> 670415-2 670414-2 (matched)
design	clamp-on short response time, with connector
type	Pt100
connection	4-wire
measuring range	-50...+250 °C
accuracy T	$\pm(0.15 \text{ °C} + 2 \cdot 10^{-3} \cdot T \text{ [°C]})$ class A
accuracy ΔT (2x Pt matched according to EN 1434-1)	$\leq 0.1 \text{ K}$ ($3 \text{ K} < \Delta T < 6 \text{ K}$), more corresponding to EN 1434-1
response time	s 8 (t_{50} , $T_1 = 25 \text{ °C}$, $T_2 = 60 \text{ °C}$)
housing material	PEEK, stainless steel 304 (1.4301), copper
degree of protection	IP54
dimensions	
length l	mm 14
width b	mm 30
height h	mm 27
dimensional drawing	
weight	kg 0.32 (without connector)
accessories	
thermal conductivity paste 200 °C	x
thermal conductivity foil 250 °C	x
plastic protection plate, insulation foam	x

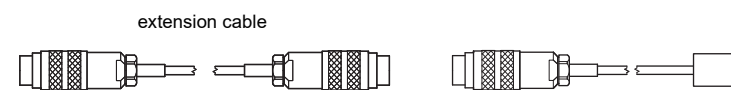
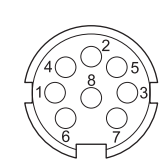
Connection system			
direct connection/connection with extension cable			
extension cable			
			
Connection			
	temperature probe	extension cable	connector
			pin
	red	grey	2
	red/blue	red	6
	white/blue	blue	1
	white	white	7
Cable			
	temperature probe	extension cable	
type	4 x 0.22 mm ²	LIYCY 8 x 0.14 mm ²	
standard length	m 3	5/10/25	
max. length	m -	200	
ambient temperature	°C -30...+250	-25...+80	
min. bend radius	mm 27	68	
cable jacket			
material	PFA	PVC	
outer diameter	mm 3.8 ±0.15	4.8 ±0.2	
colour	black	grey	

Fixation

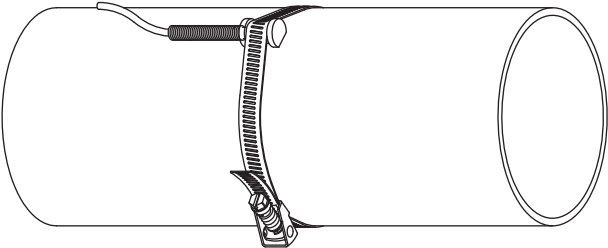
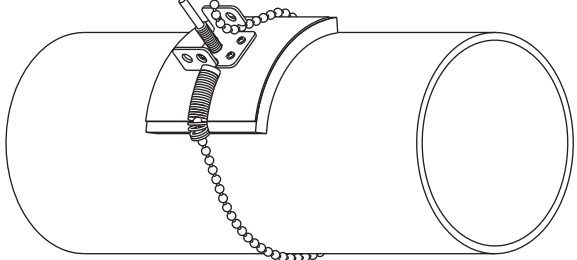
<p>tension strap PT12N</p> 	<p>material: stainless steel 301 (1.4310), 410 (1.4006) thermal insulation necessary</p>
<p>ball chain PT12F</p> 	<p>material: stainless steel 316L (1.4404) length: 1 m</p>

Wall thickness measurement (optional)

The pipe wall thickness is an important pipe parameter which has to be determined exactly for a good measurement. However, the pipe wall thickness often is unknown.

The wall thickness probe can be connected to the transmitter instead of the flow transducers and the wall thickness measurement mode is activated automatically.

Acoustic coupling compound is applied to the wall thickness probe which then is placed firmly on the pipe. The wall thickness is displayed and can be stored directly in the transmitter.

Technical data

		DWR1NZ7
item number		600522-0
measuring range ¹	mm	1...250
resolution	mm	0.01
accuracy		1 % ±0.1 mm
fluid temperature	°C	-20...+200, short-time peak max. 500
cable		
type		2616
length	m	1.5

¹ The measuring range depends on the attenuation of the ultrasonic signal in the pipe. For strongly attenuating plastics (e.g. PFA, PTFE, PP) the measuring range is smaller.

Cable

		2616
ambient temperature	°C	<200
cable jacket		
material		FEP
outer diameter	mm	5.1
colour		black
shield		x

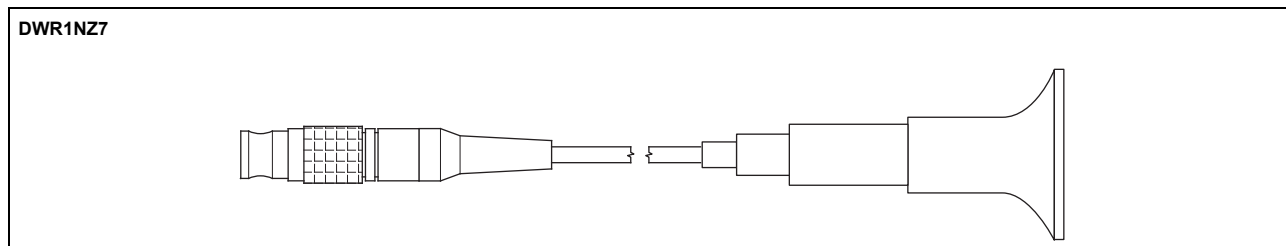

For more information: **Emerson.com**

© 2025 Emerson. All rights reserved.

Emerson Terms and Conditions of Sale are available upon request.
The Emerson logo is a trademark and service mark of Emerson Electric Co. Flexim is a mark of one of the Emerson family of companies. All other marks are the property of their respective owners.