



**BIO**

# **FITOCLIMA WALK-IN PL / PLH**

MULTI-TIER PLANT GROWTH CHAMBERS  
CONTROLLED ENVIRONMENT GROWTH ROOMS.



● ● ● ●  
**aralab**





**ARALAB** is a company specialized in designing, developing, manufacturing and servicing of high quality climatic chambers and controlled environment rooms.

Since 1985 we have been perfecting ways to create and control temperature, humidity, light, air flow and many other environmental conditions.

Only the highest quality components are used to manufacture our chambers so customers can have the best equipment for their research and testing purposes.

**Control the Environment. Your Own Climate.**



**Aralab growth chambers provide the control and flexibility to meet the evolving needs of researchers and research requirements through time.**

#### COMMON APPLICATIONS INCLUDE

- PLANT GROWTH
- TISSUE CULTURE / IN-VITRO
- ARABIDOPSIS
- GERMINATION
- ALGAE RESEARCH
- ENTOMOLOGY
- INSECT REARING
- OTHER LIFE SCIENCES APPLICATIONS



#### KEY FEATURES

- Temperature, Humidity, Light intensity and Air Flow controlled with consistent precision through the years.
- Adaptive future proof design with easily removable trays and height adjustable shelves.
- Lighting options to suite multiple research requirements and stages of plant development.
- All environmental conditions easily programmable with the new ClimaPlus® multicolour touchscreen interface.
- Stainless steel shelves for maximum resistance, durability and easy cleaning.
- Research protection features, with configurable high/low temperature and humidity alarms and automatic remote notifications.











## **MULTI-TIER PLANT GROWTH ROOMS**

CONTROLLED ENVIRONMENT ROOMS WITH MULTI-TIER GROWTH MODULES SEPERATED BY A CENTER AISLE. WITH INDEPENDENT LIGHT CONTROL IN EACH GROWTH MODULE AND PRECISE SIMULATION OF ALL ENVIRONMENTAL CONDITIONS.

## TECHNICAL SPECIFICATIONS

### ● ● ● ● FITOCLIMA MULTI-TIER 'WALK-IN' GROWTH ROOMS

<b>TEMPERATURE RANGE</b> <sup>[1]</sup>		Lights On: +5°C to +45°C Lights Off: 0 °C to +45°C
<b>TEMPERATURE UNIFORMITY IN SPACE</b>		± 1,0°C (Lights Off)
<b>HUMIDITY RANGE</b> <sup>[1]</sup> (PLH Models)		Lights On: 40 to 80% rH Lights Off: 40 to 90% rH
<b>HUMIDITY UNIFORMITY IN SPACE</b>		± 2 % rH (Lights Off)
<b>TIERS / SHELVES / LIGHT BANKS</b>		Flexible interior configuration, allowing from 2 to 3 tiers on each side of the chamber. Number of shelves and light banks dependent on chamber size and tiers. Admissible weight load: 200Kg per shelf.
<b>STANDARD GROWTH AREA</b> <sup>[2]</sup> FitoClima 5.000 FitoClima 12.000 FitoClima 20.000 FitoClima 25.000		0,75 m <sup>2</sup> per shelf (1 500mm x 500mm) 4,5 m <sup>2</sup> 4,5 m <sup>2</sup> 9 m <sup>2</sup> 13,5 m <sup>2</sup> 18 m <sup>2</sup>
<b>GROWTH HEIGHT</b>		Approximately 45cm per shelf / tier with the 3 tier configuration, and 77cm with 2 tier configuration. More or less growth height can be configured in 4,5cm increments.
<b>LIGHT TYPE AND INTENSITY</b> <sup>[3]</sup>		
<b>Light Type</b>		<b>Approximate intensity per shelf (±10%)</b>
<b>LED lights in Cool-White. 4 tubes per shelf (Config 1)</b>		+300 µmol/m <sup>2</sup> /s (+ 21.500 Lux)
<b>LED lights in Cool-White. 8 tubes per shelf (Config 2)</b>		+600 µmol/m <sup>2</sup> /s (+ 43.000 Lux)
<b>High Performance LED modules</b>		+1 000 µmol/m <sup>2</sup> /s (+ 74.000 Lux)
<b>AIRFLOW SPEED</b>		Between 0,3 to 1 meter per second. Adjustable by set point % at the touch screen controller.

[1] Temperature and Humidity performances with Lights ON can be affected by the chosen light configuration and light intensity set-point. Due to heat dissipation from the lamps - depending on the chosen type of light solution - high light intensities can affect Temperature and Humidity performances and Uniformity values. Please consult Aralab for specific information regarding the combination of light types, intensities, and how they can affect temperature and humidity performances.

[2] Other shelf dimensions available. Standard configuration assumes 3 tiers of four LED tubes shelf on each sides.

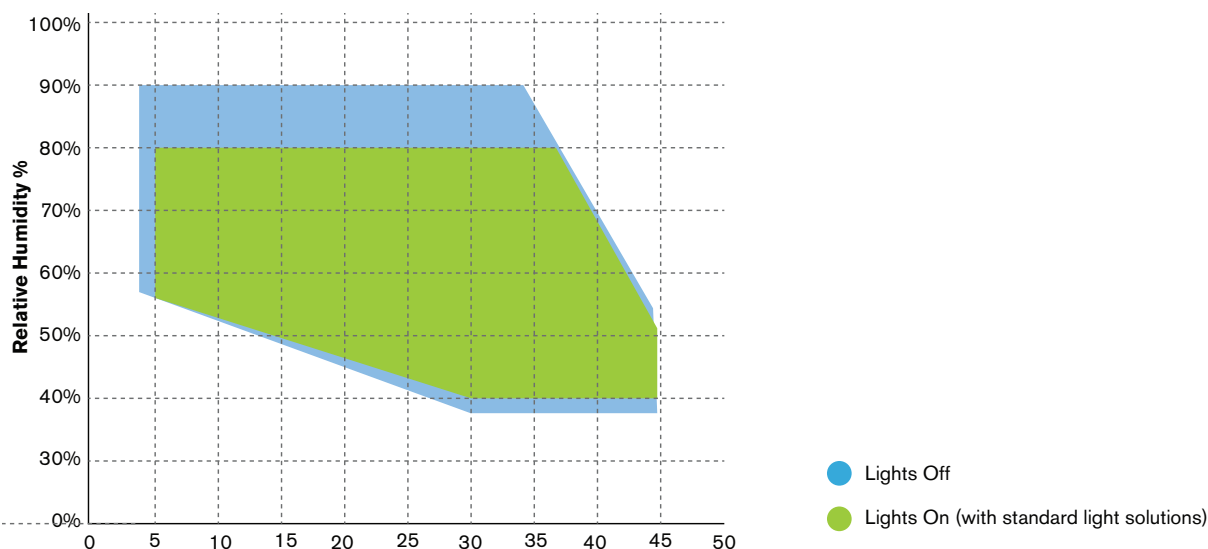

[3] Measurements at 150mm from light source at 25°C. Other lighting combinations available.

### ● ● ● ● TEMPERATURE & HUMIDITY WORKING RANGE



## DIMENSIONS AND DRAWINGS

### ● ● ● ● FITOCLIMA 5.000

<b>EXTERNAL DIMENSIONS (HxWxD) (mm)</b>		2 610 x 2 225 x 2 160 (3 250 with open door)
<b>INTERNAL DIMENSIONS (HxWxD) (mm)</b>		2 040 x 2 010 x 1 610

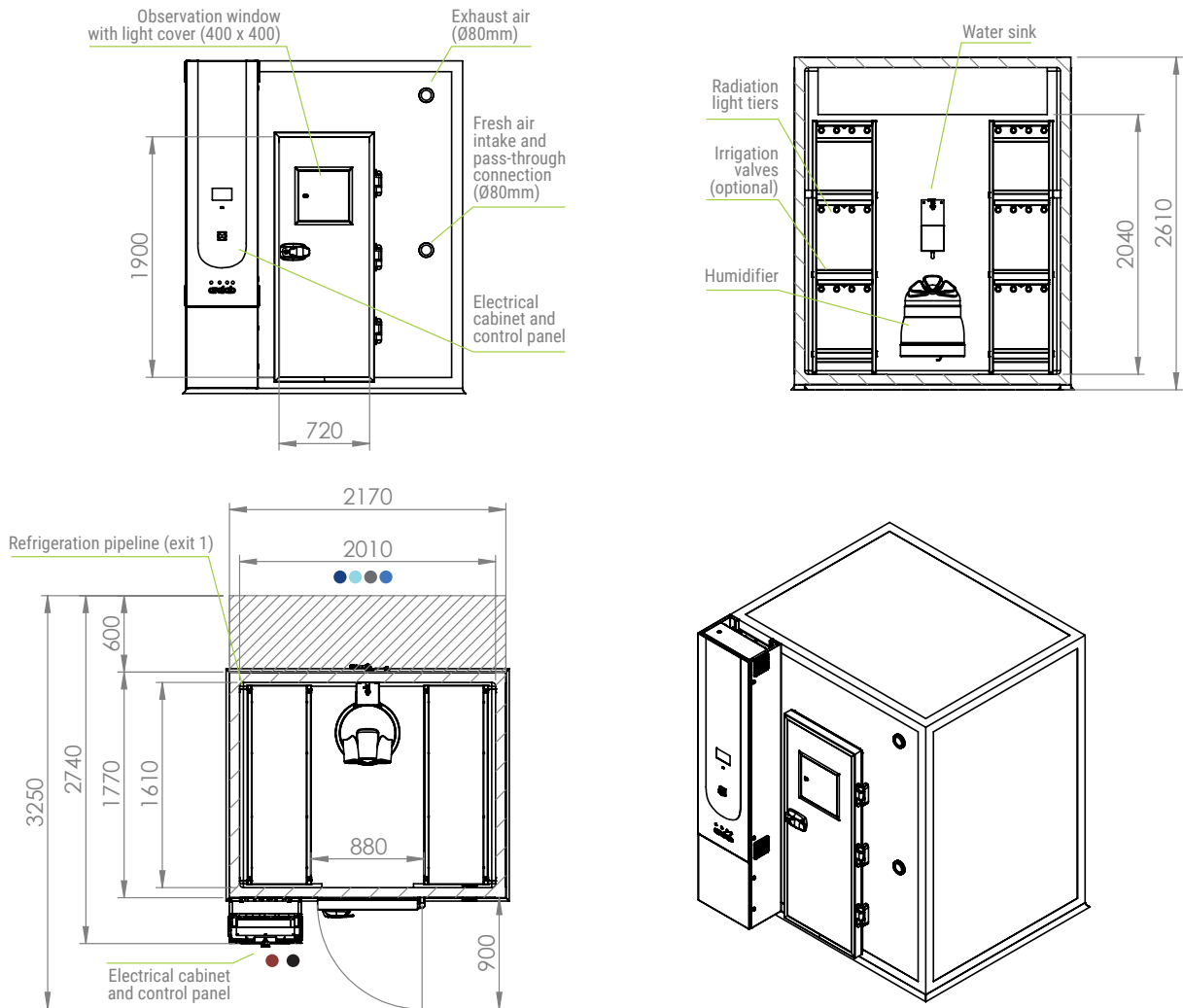

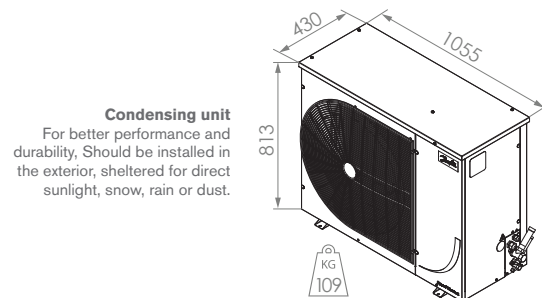

- Standard refrigeration system is air cooled.
- Services hub installation needs:
  - 3/4" demineralized water supply.  
Conductivity: <math>< 50 \mu\text{S}/\text{cm}</math>, TDS <math>< 35\text{PPM}</math>.  
Pressure: 1-5 BAR.  
Maximum theoretical water consumption 6,5L/h.
  - 20mm water drain at floor level, female connection.
  - 3/4" tap water supply.
  - 3/4" irrigation valve system.
- Electrical cabinet installation needs:
  - Supply power: 400VAC, 50Hz, (60 Hz Upon Request), 25A / 3-Phase + Neutral + Ground.  
Electrical protection: Circuit breaker 3 x 25A + N with 30mA differential.  
3-Phase electrical cable RV-K 5G4 on the top.
  - RJ45 Ethernet socket communication port on the top.
- Equipment Weight (approximate): 715 kg.



**Condensing unit**  
For better performance and durability, Should be installed in the exterior, sheltered for direct sunlight, snow, rain or dust.

## DIMENSIONS AND DRAWINGS

### FITOCLIMA 12.000

<b>EXTERNAL DIMENSIONS (HxWxD) (mm)</b>		2 610 x 2 225 x 4 360 (4 900 with open door)
<b>INTERNAL DIMENSIONS (HxWxD) (mm)</b>		2 040 x 2 010 x 3 210

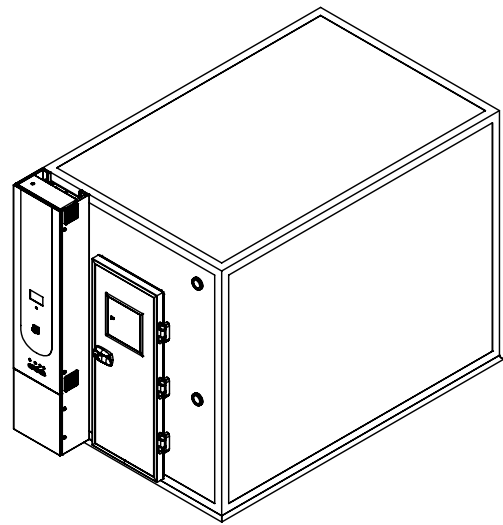
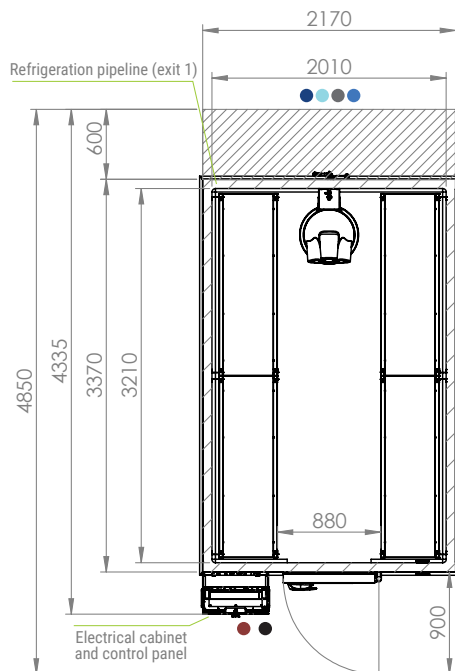
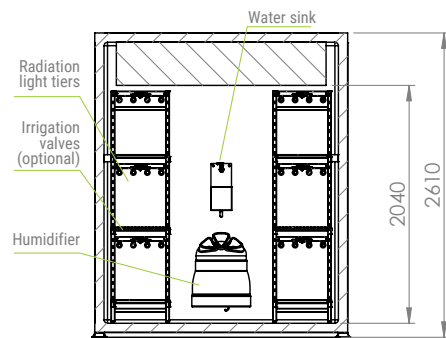
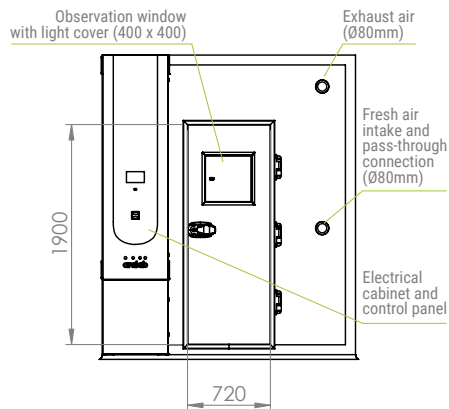

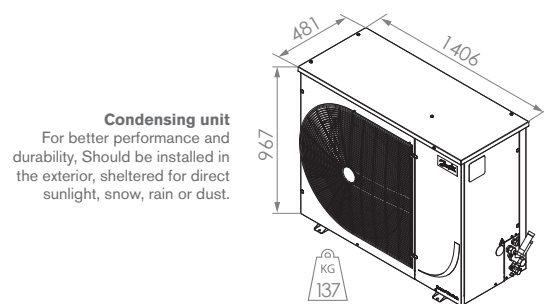

- Standard refrigeration system is air cooled.
- Services hub installation needs:
  - 3/4" demineralized water supply.  
Conductivity: <math>< 50 \mu\text{S}/\text{cm}</math>, TDS <math>< 35\text{PPM}</math>.  
Pressure: 1-5 BAR.  
Maximum theoretical water consumption 6,5L/h.
  - 20mm water drain at floor level, female connection.
  - 3/4" tap water supply.
  - 3/4" irrigation valve system.
- Electrical cabinet installation needs:
  - Supply power: 400VAC, 50Hz (60 Hz upon request), 25A / 3-Phase + Neutral + Ground.  
Electrical protection: Circuit breaker 3 x 25A + N with 30mA differential.  
3-Phase electrical cable RV-K 5G4 on the top.
  - RJ45 Ethernet socket communication port on the top.
- Equipment Weight (approximate): 1 050 kg.



## DIMENSIONS AND DRAWINGS

### ● ● ● ● FITOCLIMA 20.000

<b>EXTERNAL DIMENSIONS (HxWxD) (mm)</b>		2 610 x 2 225 x 5 960 (6 500 with open door)
<b>INTERNAL DIMENSIONS (HxWxD) (mm)</b>		2 040 x 2 010 x 4 810

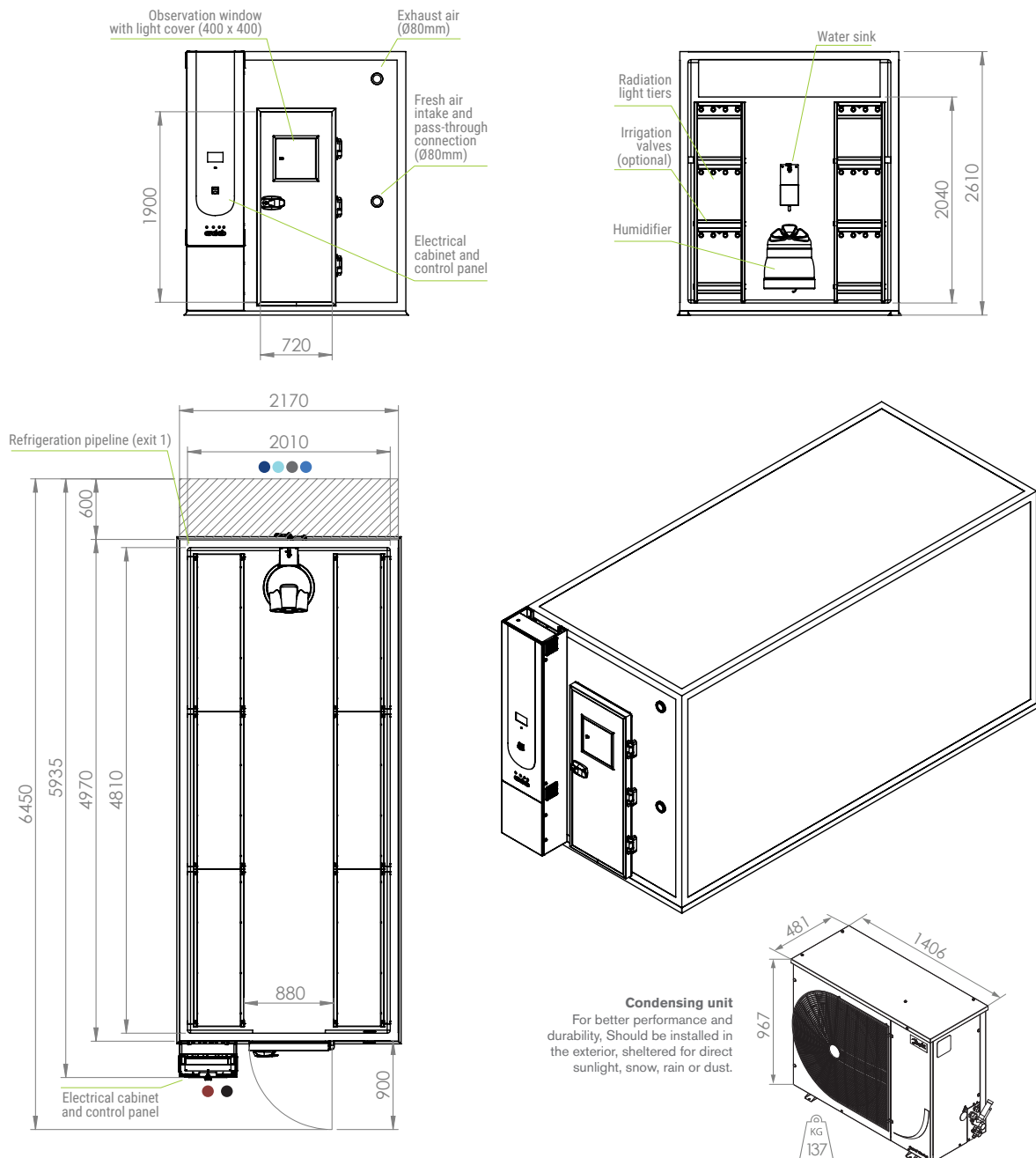

- Standard refrigeration system is air cooled.
- Services hub installation needs:
  - 3/4" demineralized water supply.  
Conductivity: <math><50\mu\text{S}/\text{cm}</math>, TDS <math><35\text{PPM}</math>.  
Pressure: 1-5 BAR.  
Maximum theoretical water consumption 6,5L/h.
  - 20mm water drain at floor level, female connection.
  - 3/4" tap water supply.
  - 3/4" irrigation valve system.

- Electrical cabinet installation needs:
  - Supply power: 400VAC, 50Hz (60 Hz upon request), 25A / 3-Phase + Neutral + Ground.
  - Electrical protection: Circuit breaker 3 x 25A + N with 30mA differential.
  - 3-Phase electrical cable RV-K 5G4 on the top.
  - RJ45 Ethernet socket communication port on the top.
- Equipment Weight (approximate): 1 400 kg.

## DIMENSIONS AND DRAWINGS

### FITOCLIMA 25.000

<b>EXTERNAL DIMENSIONS (HxWxD) (mm)</b>		2 610 x 4 225 x 4 360 (4 900 with open door)
<b>INTERNAL DIMENSIONS (HxWxD) (mm)</b>		2 040 x 4 010 x 3 210

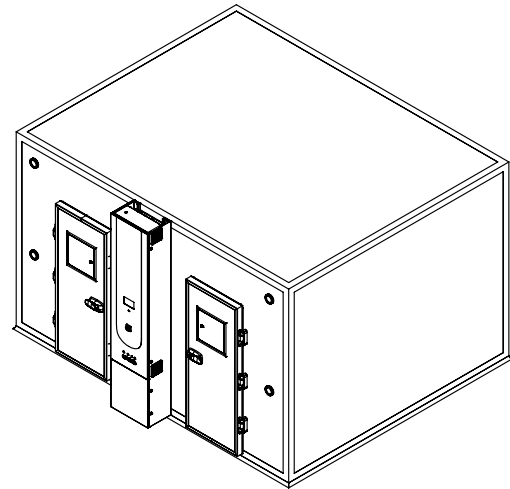
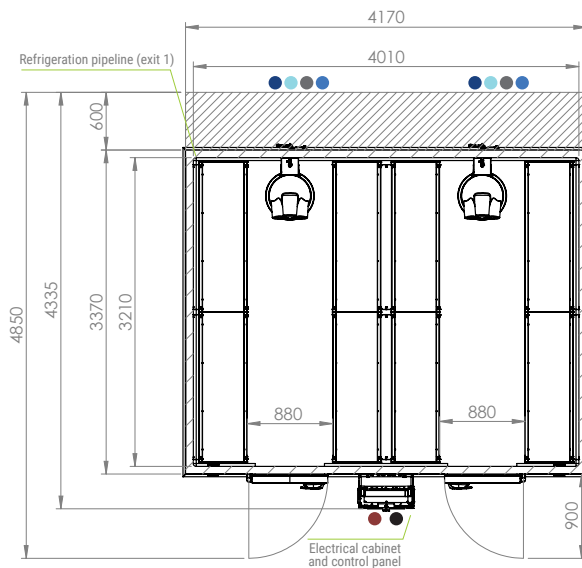
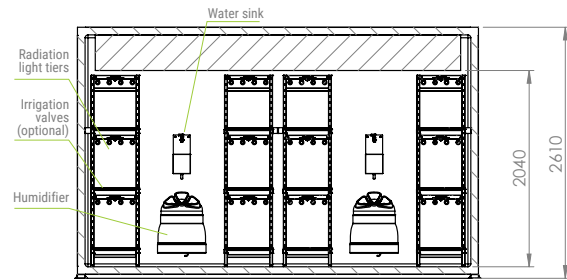
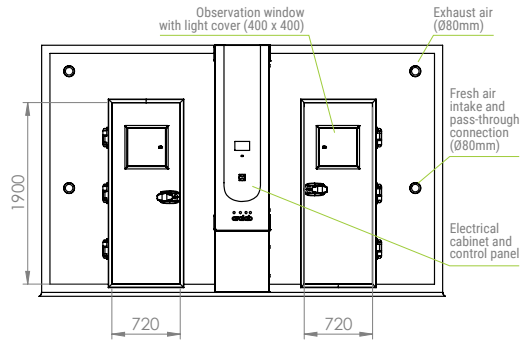

- Standard refrigeration system is air cooled.
- Services hub installation needs:
  - 3/4" demineralized water supply.  
Conductivity: <math><50\mu\text{S}/\text{cm}</math>, TDS <math><35\text{PPM}</math>.  
Pressure: 1-5 BAR.
  - 20mm water drain at floor level, female connection.
  - 3/4" tap water supply.
  - 3/4" irrigation valve system.
- Electrical cabinet installation needs:
  - Supply power: 400VAC, 50Hz (60 Hz upon request), 32A / 3-Phase + Neutral + Ground.  
Electrical protection: Circuit breaker 3 x 32A + N with 30 mA differential.  
3-Phase electrical cable RV-K 5G6 on the top.
  - RJ45 Ethernet socket communication port on the top.
- Equipment Weight (approximate): 1 700 kg.

**Condensing unit**  
For better performance and durability, Should be installed in the exterior, sheltered for direct sunlight, snow, rain or dust.

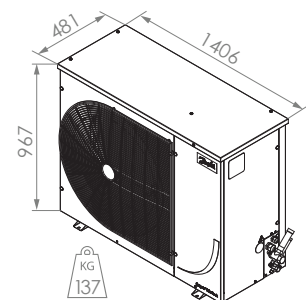

## LIGHT TYPES AND INTENSITIES

### COOL-WHITE LED 4000K

Shelves with 4 tubes: 400  $\mu\text{mol}/\text{m}^2/\text{s}$  (at 150mm).  
Shelves with 8 tubes: 600  $\mu\text{mol}/\text{m}^2/\text{s}$  (at 150mm).

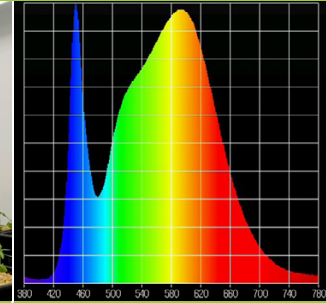

### ENHANCED COOL-WHITE LED

(White 4000K LED with UVA and FR compensation).

Shelves with 4 tubes: 300  $\mu\text{mol}/\text{m}^2/\text{s}$  (at 150mm).  
Shelves with 8 tubes: 600  $\mu\text{mol}/\text{m}^2/\text{s}$  (at 150mm).

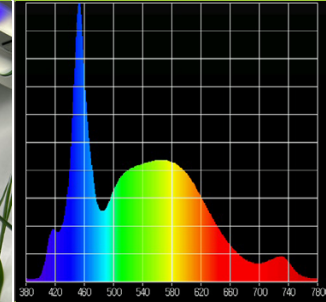
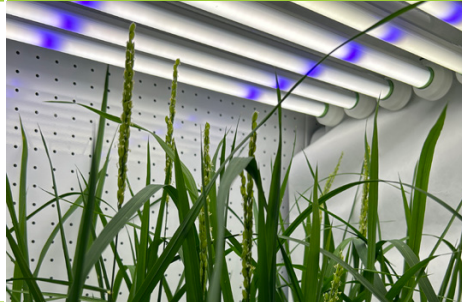

### WARM-WHITE LED 3000K

Shelves with 4 tubes: 300  $\mu\text{mol}/\text{m}^2/\text{s}$  (at 150mm).  
Shelves with 8 tubes: 600  $\mu\text{mol}/\text{m}^2/\text{s}$  (at 150mm).

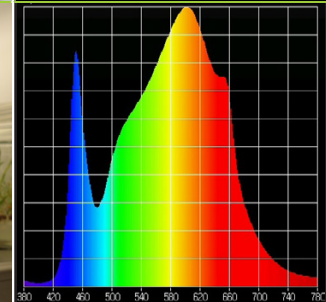

### HP LED 3500K

Per shelf : 1 400  $\mu\text{mol}/\text{m}^2/\text{s}$  (at 500mm) and  
3 000  $\mu\text{mol}/\text{m}^2/\text{s}$  (at 150mm).

Note: usually used in single-tier rooms.

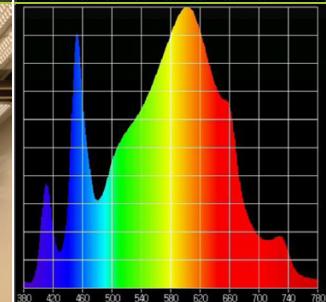

### 8IIA CONFIGURABLE SPECTRA LED MODULE

Per shelf: 660  $\mu\text{mol}/\text{m}^2/\text{s}$  (at 500mm) and  
1 300  $\mu\text{mol}/\text{m}^2/\text{s}$  (at 150mm).

Note: Variable spectrum LED module. Intensity will be spectra dependent. Above measurements are with all channels turned ON.

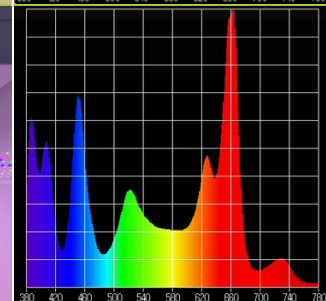
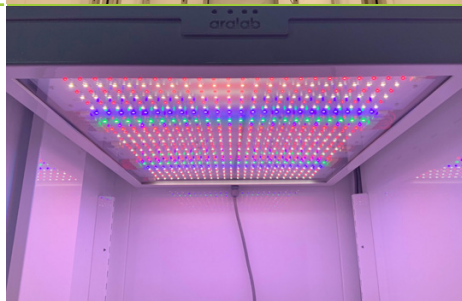

### INTEGRATION OF THIRD PARTY LED

Per shelf: from 400  $\mu\text{mol}/\text{m}^2/\text{s}$  (at 150mm)  
to >1 000  $\mu\text{mol}/\text{m}^2/\text{s}$  (at 150mm).

Application and Specifications dependent.



Aralab can integrate LED solutions from various renowned manufacturers. The spectrum is typically application-dependent and tailored to meet customer specifications.

## EQUIPMENT DESCRIPTION



### CONSTRUCTION

- Exterior: EN 14509 sandwich type high density injected polyurethane foam modular panels, 80 mm thick (other thicknesses available for different specific insulation requirements) with galvanized steel in light gray plastic finish.
- Floor: slip resistant AISI 304 stainless steel floor.
- Walls: Galvanized steel with white epoxy paint.
- Shelving and trays: highly resistant, height adjustable, AISI 304 stainless steel
- 80mm Ø entry-port.
- New generation multi-color touch-screen ClimaPlus© controller.
- Door with sealing gasket, observation window, key lock and safety opening mechanism from the inside.
- Open door alarm with configurable time-out function.
- Free slots for connecting and integrating external devices with the ClimaPlus controller (CO<sub>2</sub>, Auto Irrigation, Aeration, Radiometers and other).
- Entomology and Insect rearing rooms have 'flicker-free' ceiling lights and special low-noise blower. In addition to a particulate air filter located on the evaporator inlet, the system is also protected by a phenolic resins coating.



### CLIMATIC CONTROL

- Air cooled, R513A refrigeration gas, GWP of 573, by sealed condenser group. Optional water cooled.
- Dual heating technology with hot gas by-pass and stainless steel electric heaters.
- Humidification by centrifugal humidifier with very low power consumption and hygienic automatic washing cycles.
- Dehumidification by condensation on the cooling system evaporator.
- PT100 RTD temperature sensor and capacitive humidity sensor.



### AIR FLOW

- Dynamic airflow with EC (variable) blower.
- Forced in vertical and downward direction through ceiling plenum (perforated walls upon request).
- Horizontal airflow across the shelves to assure uniformity to all growth area.
- Air renovation through adjustable port-holes.
- Airflow speed adjustable at the ClimaPlus© controller.



### RESEARCH PROTECTION AND SECURITY

- Independent thermostats for maximum and minimum temperature limits.
- Automatic cut-off function, in case of excessive heating or cooling.
- Configurable maximum and minimum temperature and humidity limits.
- Visual and audible alarms for temperature and humidity band limits.

## CLIMAPLUS CONTROLLER HMI

- Programmable Logic Controller exclusively developed by Aralab for FitoClima chambers.
- Multi-language, easy-to-use touch-screen interface (EN, FR, DE, IT, PT, ES and other languages on request).
- 90mm x 155mm (7 inch) multicolor display.
- Controls every environmental variable available for any specific FitoClima model (Temperature, Humidity, Lights, Airflow, CO2 and connected external devices).
- Friendly program editor, allowing the design of complex and comprehensive climatic simulation programs.
- User access definition (Viewer, User, Admin) with alphanumeric password protection of the controller functions.
- Content and research protection feature, with configurable High, Low and Band Temperature and Humidity alarms and automatic notifications.
- Managing, monitoring and recording of all alarms.
- Non-volatile memory, allowing the automatic restart of previously defined set-points or on-going programs due to power failure, without losing data.
- Real-time monitoring of all the functions and active components of the equipment, allowing for a fast and accurate diagnostic in case of malfunction.
- Possibility to control and program events by external commands and with external devices.
- Secure Remote Access through ClimaPlus VNC Server.
- Ethernet port for connecting logging computer to the chamber controller.
- ClimaPlus controller functions also available at the PC/Laptop with the FitoLog software pack.

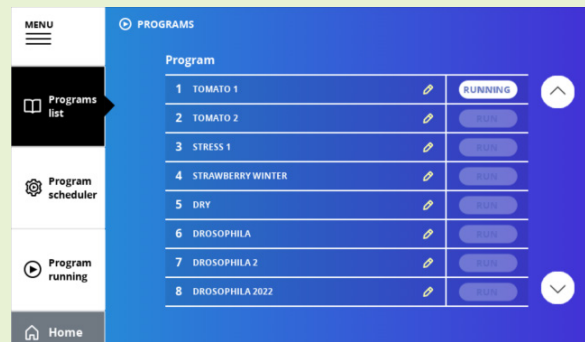
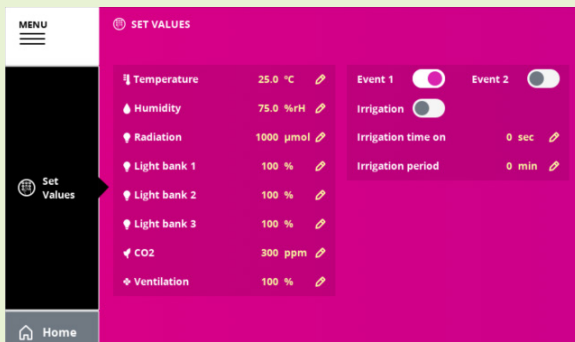
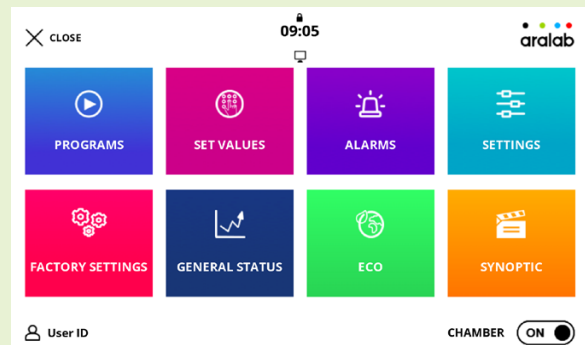

## FITOLOG SOFTWARE

The FitoLog software pack is a set of applications designed to facilitate the managing, monitoring and recording of programs and data from the FitoClima chambers. It consists of 3 applications: **FitoLog**, **FitoLogView** and **FitoProgram**.



### FITOLOG

Records and displays in real time all data and details related to the set-points, running variables and equipment behaviour. It also retrieves information about the active components of the chamber, running processes, errors, alarms and allows the configuration of periodic or alarm triggered remote notifications (by email or SMS, depending on existing connections and accessories).

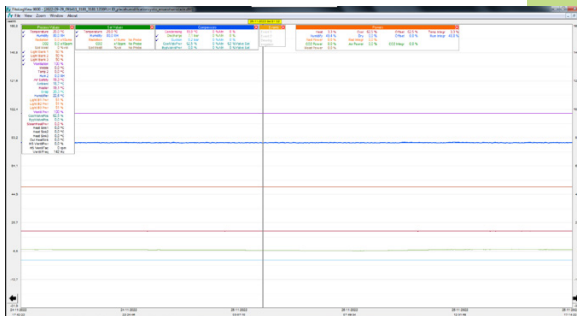

### FITOLOGVIEW

It is a working tool to process the data recorded by the FitoLog program. One can view, print and export the log contents to other file types, and analyse the data in other data management software.

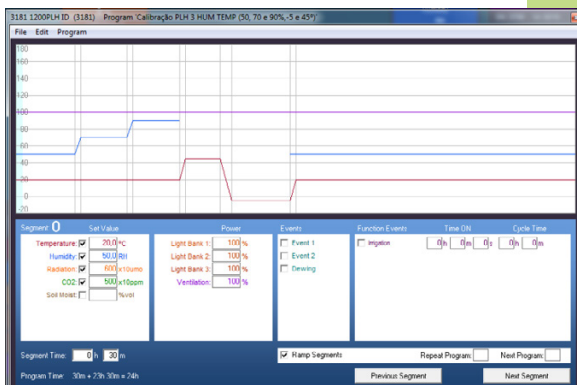

### FITOPROGRAM

This application simplifies the creation of programs and its integration on the chamber ClimaPlus controller. Up to 32 programs, each with 24 segments, can be designed and linked to create detailed environmental profiles and simulations.

## RESEARCH SECURED WITH ALARMS, NOTIFICATIONS, FAST DIAGNOSTICS AND PROMPT TROUBLESHOOTING

With FitoLog it is possible to gather data from each of the chambers systems, which makes it a very useful tool to diagnose any necessary maintenance. This tool works as the “black box” of the equipment, giving Aralab technicians the necessary data to remotely carry out a fast and efficient diagnostic. All that is needed is a FitoLog file.

## COMMON ACCESSORIES

### PLEASE CONSULT ARALAB FOR OTHER ITEMS

FitoLog® software pack for PC/Laptops, enabling data monitoring, logging and managing operations directly on a computer.

CO<sub>2</sub> monitor and controlling unit.

CO<sub>2</sub> scrubber

Light intensity control in  $\mu\text{mol}/\text{m}^2/\text{s}$  with the integration of an internal quantum light meter.

LED modules with fixed spectral distribution.

LED modules with adjustable spectral distribution.

Extra drying capacity.

Additional entry ports.

Additional electrical plugs.

Water-cooled condenser.

Positive/Negative pressures with HEPA filters.

Phenolic coating for Entomology/Insect rearing rooms.

Irrigation function for automated watering and plant nurturing.

Aeration kit for Algae Research and Hydroponic cultures.

Integrated water tank with electric pump and security valve.

Hydroponic system with PH and EC control and monitoring.

Additional internal electrical connection sockets.



Quantum Light Meter



Hydroponic Irrigation (pH and EC control)



CO2 control and monitoring

## COMMON APPLICATIONS AND FITOCLIMA MODELS MATRIX

### TYPICAL APPLICATIONS

### FITOCLIMA CONFIGURATION

Tissue culture

Configuration 1

Small plants (e.g. Arabidopsis)

Configuration 1

Medium plants (e.g. Tomato, Colza, Rice)

Configuration 2

## MULTI-TIER GROWTH ROOMS - CUSTOMER APPLICATIONS

CUSTOMER SPECIFICATIONS AND ACCESSORIES MAY RESULT IN DIFFERENT PRODUCT IMAGES



TISSUE CULTURE ROOMS



ARABIDOPSIS RESEARCH GROWTH CHAMBERS



VEGETABLE RESEARCH ROOMS

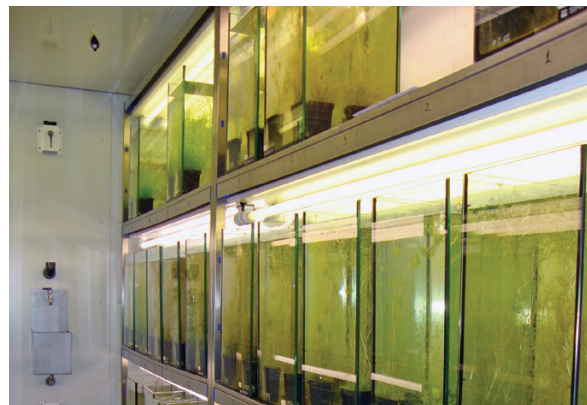

ALGAE RESEARCH AT MARINE BIOLOGY CENTER



AGTECH VEGETABLE PRODUCTION ROOM



DROSOPHILA REARING AND STOCK ROOM

Features and specifications are subject to change. Aralab continuously studies ways to further develop its products to achieve better performances and overall product quality. As a result, characteristics and specifications provided in this document may be subject to changes.

Let's meet!

[aralab@aralab.pt](mailto:aralab@aralab.pt)

[www.aralab.pt](http://www.aralab.pt)

T: +351 219 154 960



Configure your chamber



See it on the Showroom



[f/AralabChambers](https://www.facebook.com/AralabChambers)

[in/company/aralab](https://www.linkedin.com/company/aralab)

[y/user/AralabChambers](https://www.youtube.com/user/AralabChambers)

[x/Aralab\\_](https://www.instagram.com/Aralab_)

[@aralabchambers](https://www.instagram.com/aralabchambers)



**Control the environment**  
Your own climate