

TESTING
TESTA 1.000 CT SUN
CLIMATIC TESTING
SOLAR RADIATION CHAMBER





ARALAB is a company specialised in designing, developing, manufacturing and servicing of high quality climatic chambers and controlled environment rooms.

Since 1985 we have been perfecting ways to create and control temperature, humidity, light, air flow and many other environmental conditions.

Only the highest quality components are used to manufacture our chambers so customers can have the best equipment for their research and testing purposes.

Control the Environment. Your Own Climate.



TESTA temperature and humidity testing chambers offer highly precise and reproducible conditions for climatic and temperature testing in many industries.

COMMON APPLICATIONS INCLUDE:

- ENVIRONMENTAL TESTING
- ELECTRONICS, AUTOMOTIVE, AEROSPACE,
- BUILDING MATERIALS, MILITARY EQUIPMENT, MATERIALS IN GENERAL
- RESEARCH & DEVELOPMENT
- QUALITY CONTROL
- PRODUCTION FACILITIES





KEY FEATURES

- The most advanced technology in climate control
- Internal aerodynamic optimisation to ensure uniformity of climatic conditions
- Time saving features with easily configurable testing programs that can run, start and stop automatically
- Highly resistant stainless steel interior for maximum durability and easy cleaning
- Flexible interior with height adjustable and removable stainless steel shelves
- Nonpolluting construction and cooling system
- Compliant with international standards and requirements EN, IEC, DIN, ISO, NP and UNE



TESTA 1.000 DIMENSIONS AND DRAWINGS

● ● ● ● TESTA TT / TESTA CT 1.000 SOLAR RADIATION CHAMBER

EXTERNAL DIMENSIONS (HxWxD) (mm)		2 480 x 1 359 x 1 836
INTERNAL DIMENSIONS (HxWxD) (mm)		910 x 984 x 1.052

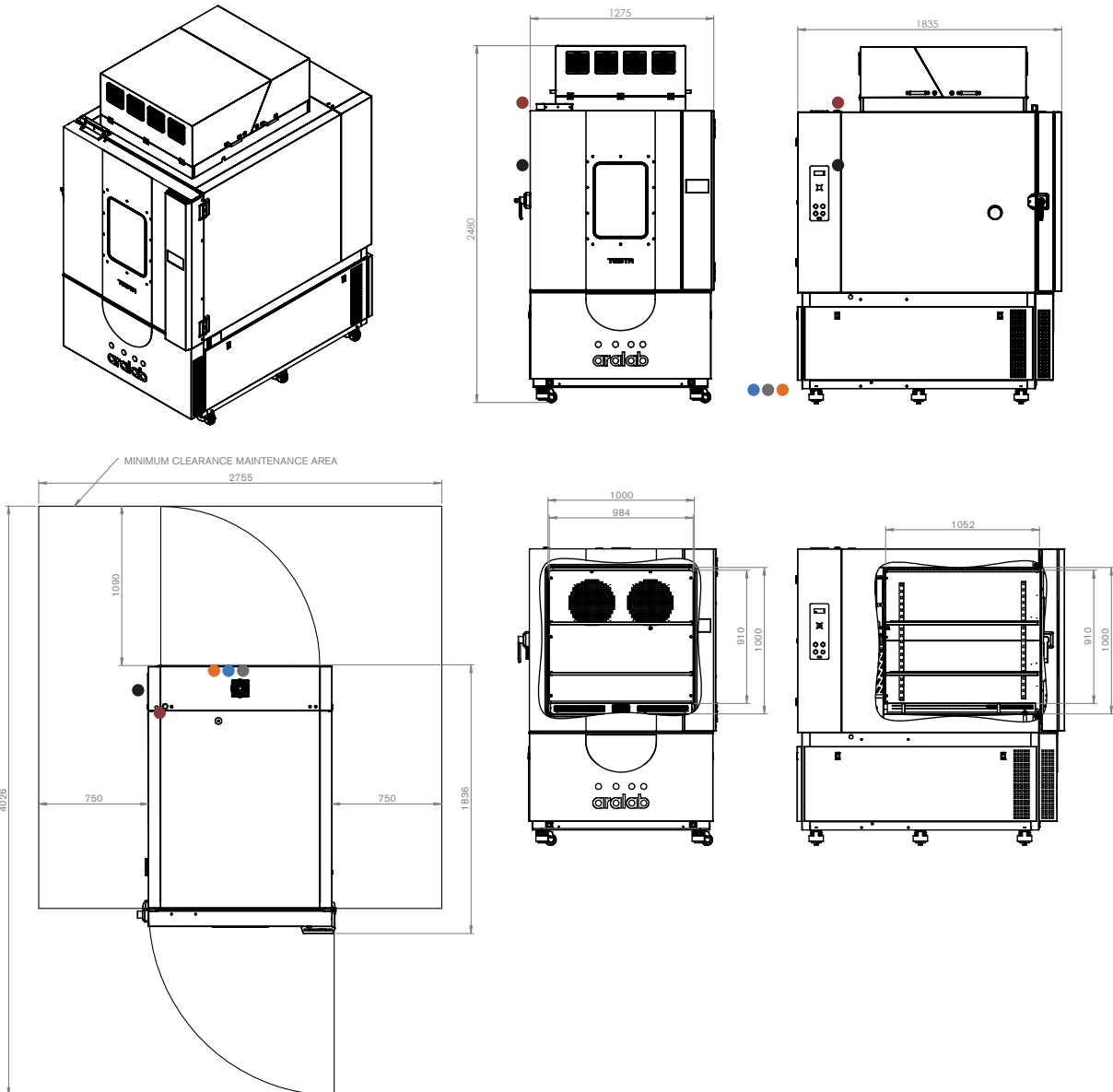

1. **Standard refrigeration system is air cooled**
2. **Services hub installation needs:**
 - ½" demineralized water supply
Conductivity: <math>< 50 \mu\text{S}/\text{cm}</math>, TDS <math>< 35\text{PPM}</math>
 - 20mm water drain at floor level female connection
3. **Electrical cabinet installation needs:**

Supply power ECP50:
400VAC, 50Hz, 32A / 3-Phase + Neutral + Ground
Electrical protection: Circuit breaker 3 x 32A + N with 300mA differential
3-Phase electrical cable RV-K 5G4 on the top

- Supply power ECP70:**
400VAC, 50Hz (60Hz upon request), 50A / 3 Phase + Neutral + Ground
Electrical protection: Circuit breaker 3 x 63A + N with 300mA differential
3-Phase electrical cable RV-K 5G10 on the top
4. **RJ45 communications port**
 - **Water cooled option (is included as standard in -70°C models)**
Intake pressure: 3 to 5 bar
Water entry and exit pipe: 1" or 28mm
Maximum temperature of water entry: 23 °C
Minimum temperature of water entry: 16 °C
Recommended temperature of water entry: 18 °C

EQUIPMENT DESCRIPTION

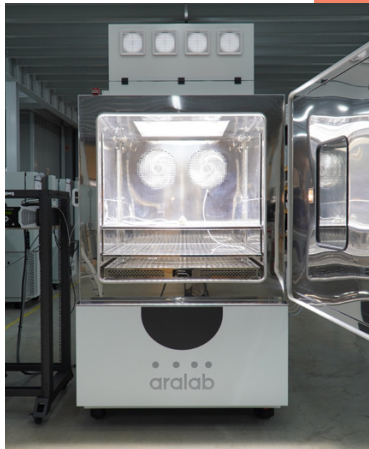

PERFORMANCE

Temperature range

Min	Irradiation Off	°C	-52 or -70
	Irradiation On	°C	-20
Max	Irradiation Off	°C	150
	Irradiation ON	°C	100

Temperature Fluctuation (K)

Irradiation Off	°C	±0,1 to ±0,5
Irradiation On	°C	±1

Humidity range

Irradiation Off	%rH	10 to 90
Irradiation On	%rH	10 to 80

Humidity Fluctuation

Irradiation Off	%rH	±0,1 to ±0,5
Irradiation On	%rH	±3

Temperature Range (in Climatic Testing)

Irradiation Off	°C	10 to 90
Irradiation On	°C	15 to 80

Humidity Range

Irradiation Off	%rH	10 to 90
Irradiation On	%rH	10 to 80

Performances measured in the center of the test area, chamber empty and stable, protected from heat radiation, and dependent on climatic set-points

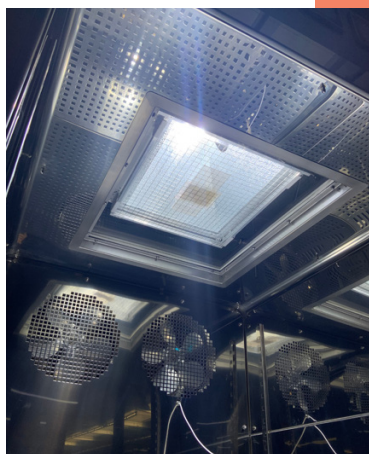

TEMPERATURE AND HUMIDITY CONTROL

TEMPERATURE SENSORS

- One (1) PT 100 Class A, located in air treatment tunnel
- One (1) PT 100 Class A, movable sensors for flexible placing inside chamber

HEATING

- By stainless steel electric heaters located in the air treatment tunnel

COOLING

- Air cooled hermetic scroll compressor group (low noise and high efficiency) with enforced ventilation and without CFC's. Water-cooled condensers are also available as standard in -70°C models or as an option for all other models.

THERMAL SECURITY

- Safety thermostat with High / Low temperature configuration, with automatic stop of all thermic systems.
- High / Low temperature alarms programmed in the controller, with mute function. This function will not stop the chamber and it is only used to record the occurrence and to call the attention of the users with an audible alarm.

HUMIDITY SENSORS

- To measure and control humidity Aralab uses two different sensor technologies: Psychrometric (EP models), Capacitive (EC models), or both (ECP models). Consult Aralab for technical support on the appropriate selection.

HUMIDITY / DRYING

- Humidity: Through thermostatic bath with dew point control
- Drying: Through thermostatic bath with dew point control and additional dry coil



ALARM

ACTIVE ALARMS LIST

Home

Mute

SECURITY

- Automatic stop function in case of water failure, with indication on the controller; High / Low Temperature alarms; High / Low humidity alarms.



CONSTRUCTION

- Interior: AISI 304 hermetical welded, vapour tight, stainless steel
- Exterior: Zinc mild steel with epoxy coating finish (color RAL 7035)
- Insulation: Rock Wool
- Interior illumination: available with optional observation window
- Door: Double silicone joints and anti-condensation heating frames (optional window)

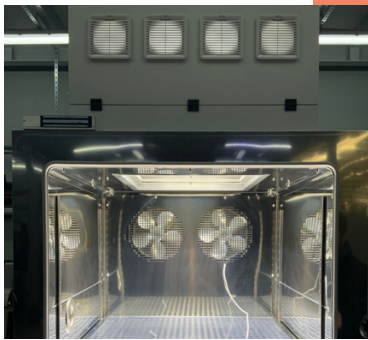

AIR FLOW / VENTILATION

- Air Flow: Forced through 2 ventilators/fans.
- Air Renovation: By lateral port, also for compensating pressure.



CUT-OFF PANEL, SECURITY AND COMMUNICATIONS

On left lateral panel of the chamber and equipped with:

- High / Low safety thermostat
- Mains Power switch
- Audible alarms
- Ethernet communications port



LAMP

- This full-spectrum lamp complies with DIN 75220.
- The solar simulation utilizes a single lamp with a power rating of 2 500W.
- The lamp housing is crafted from anodized aluminum, and the mounting components are made of stainless steel. The design ensures efficient heat dissipation at the bulb socket and reflector to minimize thermal impact on the bulb.
- Bulb replacement is designed for efficiency and speed to minimize service time. The lamp can be easily opened from the top via a specially designed bracket, facilitating quick bulb changes.
- The bulb requires approximately 3 minutes to reach operational parameters. After switch-off, the lamp can be restarted following a waiting time of approximately 10 minutes for cold ignition.
- The bulb's operational lifespan is guaranteed for 1000 hours.
- The lamp comes with a specialized bracket for securing the lamp to the chamber ceiling. The lamp is installed in an aperture within the chamber ceiling.



TECHNICAL DESCRIPTION OF THE SUN SIMULATION SYSTEM

Irradiance	1 200 W/m ² – 600 W/m ²
Power Rating	2 500 W
Irradiation Area - approx.	600 x 700 mm
Distance from radiation-sample	650 - 800 mm

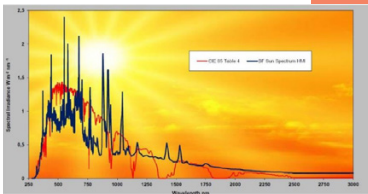

SPECTRAL

The irradiance of our simulator adheres to the global spectrum in accordance with AM1.5. The spectral match of this sun simulator complies with both IEC 60904-9 and DIN 75220 standards.

Wavelength nm	Proportion of total radiation %	Transmission of 4 mm thick glass pane %	Proportion of total radiation behind 4 mm thick glass pane %
280 to 320	0,5 ± 0,2	0,07	< 0,04
320 to 360	2,4 ± 0,6	0,61	1,8 ± 0,5
360 to 400	3,2 ^{+1,2} _{-0,8} ¹⁾	0,88	3,4 ^{+1,2} _{-0,8} ¹⁾
400 to 520	17,9 ± 1,8	0,89	19,2 ± 1,9
520 to 640	16,6 ± 1,7	0,89	17,8 ± 1,8
640 to 800	17,3 ^{+1,7} _{-4,5} ¹⁾	0,83	17,3 ^{+1,7} _{-4,5} ¹⁾
800 to 3 000	42,1 ± 8,4	0,80	40,5 ± 8,1

Non-uniformity

Our solar simulator ensures a non-uniformity level of less than ±10%.

Temporal Stability (STI + LTI)

The temporal instability of the solar simulator meets the standards of IEC 60904-9:

- Short Term Instability (STI) is less than ±2%
- Long Term Instability (LTI) is less than ±5%



ELECTRONIC POWER SUPPLY (EPS)

The lamps in our system are powered by electronic power supplies, specifically designed for use in solar simulation systems. These power supplies are equipped with a constant regulation function to stabilize the output power. The selected irradiance power is consistently regulated through the adjustment of lamp voltage and lamp current. These power supplies guarantee a power factor of 0.98.

Technical data

Mains connection	50/60 Hz, 215-240 VAC
Input power	2 800 VA nominal
Power factor	typ. 0,95
Max. Output current	28A
Open circuit voltage	about 400V
Output frequent	100Hz
Lamp connection	HAN Modular
Test voltage primary/control signals	4KV
Dimensions case without connectors	482,6 x 133 x 535 mm
Weight: about	17 kg
Ambient temperature max	50°C
Degree of protection	IP 30
Protection class	1

PROPOSED SYSTEM COMPONENTS

- BFE SUN 2500W Lamp with Osram HMI 2 500 W Bulb
- Cold Ignition Igniter
- EPSU 1 x 2 500W - Electronic Power Supply Unit
- Lamp Cables
- Indoor Filter Glass
- Borosilicate Glass
- Climaplust Controller, equipped with a Radiation application
- FitoLog Software, integrated with a Radiation application

ACCESSORIES

OPTIONAL SENSORS

Pyranometer

For the measuring of the irradiation power one pyranometer of the type Kipp & Zonen CM4 is included in the offer. The pyranometer CM4 is high temperature resistant (+150°C) and can be placed on the test vehicle during the whole test duration for closed loop regulation.

The pyranometer can be connected to a connection box inside the chamber. A data amplifier will be delivered together with the sensor.



Specifications

Spectral range (50% points)	300 to 2 800 nm
Sensitivity	4 - 10 $\mu\text{V}/\text{W}/\text{m}^2$
Response time	< 8 s
Zero offset A	< 4 W/M^2
Zero offset B	< 15 W/M^2
Directional response (up to 80° with 1 000 W/m^2 beam)	< 20 W/M^2
Temperature dependence of sensitivity (over any 50 °C interval in the range from -20 °C to +150°C)	< 3 %
Operational temperature range	-40 °C to +150 °C
Maximum solar irradiance	4 000 W/m^2
Field of view	180°

CUV5 Total UV Radiometer

CUV5 is a general-purpose instrument measuring the total UV radiation from natural sunlight for applications in meteorology and outdoor material testing. The high quality dome and diffuser provide optimized directional response. A specially designed optical filter provides sensitivity to combined UVA and UVB irradiance. The photodiode generates a voltage output linearly proportional to the UV intensity.



Specific parts of the UV spectrum such as UVA, UVB or UVE / UV Index cannot be derived from the CUV5 measurements. For measurement of these individual parameters our specific SUV models are required.

Specifications

Spectral range (overall)	280 to 400 nm
Sensitivity	300 - 500 $\mu\text{V}/\text{W}/\text{m}^2$
Temperature response	< -0.3% per °C
Response time (95%)	< 1 s
Non-linearity (0 to 100 W/m^2)	< 1 %
Maximum UVA/UVB irradiance	400 W/m^2
Operational temperature range	-40 to +80 °C
Directional response (up to 70° with 100 W/m^2 beam)	< 5%
Field of view	180°

BST Black Standard Temperature

For measurement of the temperature 1 x temperature sensor in black body design will be delivered. With the black body sensors, the temperature (°C) of the test vehicle surface can be measured. The temperature sensor is equipped with a temperature resistant connection cable with 10 m length.

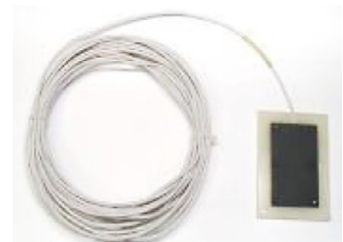

CLIMAPLUS HMI CONTROLLER

Programmable PLC exclusively developed for Aralab chambers.

Multi-language, easy-to-use touch-screen interface (EN, FR, DE, IT, PT, ES and other languages on request).

Resolution of 0,1°C for Temperature and 0,1% for Relative Humidity.

High performance temperature and humidity control with value correction in all ranges.

Capability for creating 50 programs of 50 segments each.

Internal non volatile memory for storing test data.

Automatic restart of tests due to power failure, without losing data and restarting test where it was interrupted.

Real-time monitoring of all functions and control of equipment.

Manage control settings via MODBUS/TCP.

Possibility of programming a delay of the beginning of test.

Monitoring and recording of all alarms.

Possibility of performing events by external commands.

Several outputs for connecting computers or other devices.

Alarms management.

Graphic representation of the tests and conditions.

Remote access through VNC server.

Possibility of running computer test programs and export them to the controller.

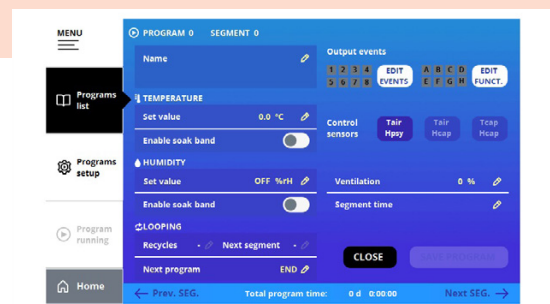
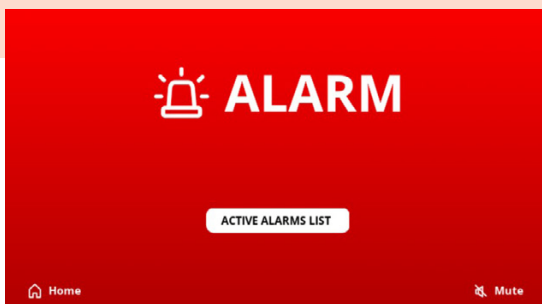
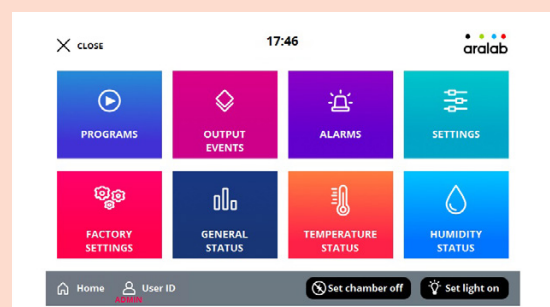
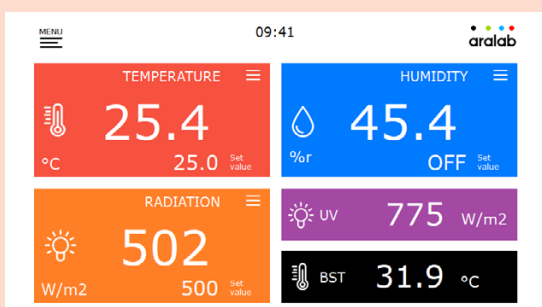

FITOLOG SOFTWARE

The FitoLog software pack is a set of applications designed to facilitate the managing, monitoring and recording of programs and data from the TESTA chambers. It consists of 3 applications: **FitoLog**, **FitoLogView** and **FitoProgram**.



FITOLOG

Records and displays in real time all data and details related to the set-points, running variables and equipment behaviour. It also retrieves information about the active components of the chamber, running processes, errors, alarms and allows the configuration of periodic or alarm triggered remote notifications (by email or SMS, depending on existing connections and accessories).

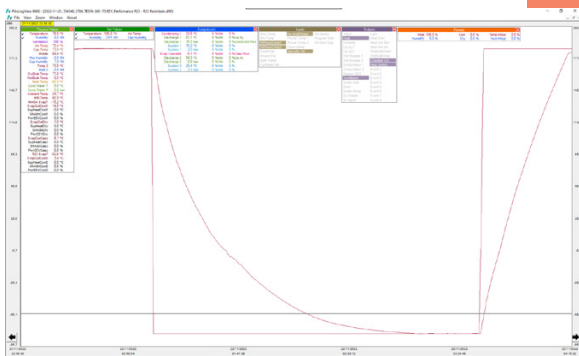

FITOLOGVIEW

It is a working tool to process the data recorded by the FitoLog program. One can view, print and export the log contents to other file types, and analyse the data in other data management software.

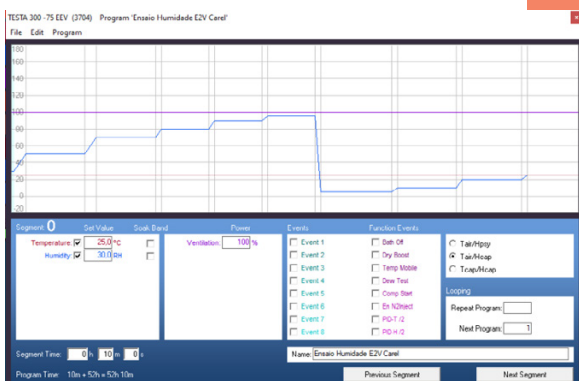

FITOPROGRAM

This application simplifies the creation of programs and its integration on the chamber CiimaPlus controller. Up to 50 programs, each with 50 segments, can be designed and linked to create detailed environmental profiles and simulations.

NOTIFICATIONS, FAST DIAGNOSTICS AND PROMPT TROUBLESHOOTING

With FitoLog it is possible to gather data from each of the chambers systems, which makes it a very useful tool to diagnose any necessary maintenance. This tool works as the "black box" of the equipment, giving Aralab technicians the necessary data to remotely carry out a fast and efficient diagnostic. All that is needed is a FitoLog file.

Let's meet!

aralab@aralab.pt

www.aralab.pt

T: +351 219 154 960



Configure your
chamber 

See it on the
Showroom 

 /AralabChambers

 /company/aralab

 /user/AralabChambers

 /Aralab_

 /aralabchambers



Control the environment

Your own climate